



Components

Véronique Beauvois, Ir.
2019-2020



Specific components

Solutions – Essential rules

- Technical vs. economical constraints
- Global concept / Early stage
- If not, the risk is additional cost (3 to 5%)
- The margin to solve the problem is decreasing when time is running
- Another risk: additional delay
- No exact solution but engineering rules to follow
- Do not neglect any element (cabling, connections to ground...)
- Step by step solution to solve the problems.



Basic passive components: R & L

- parasitic effects: parasitic R, L, C
- coil: non linear phenomena (saturation, hysteresis)
- dielectric losses (f)

$$R = [R \ L \ (\text{nH})] \ C_p \ (\text{pF})$$

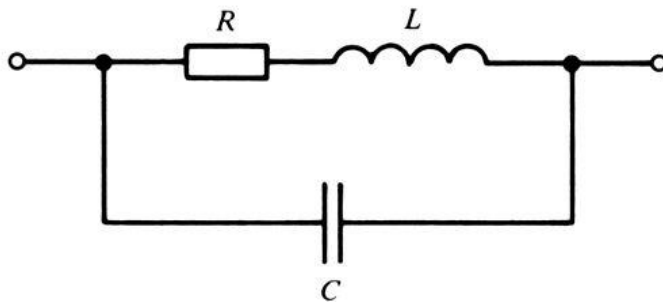

$$L = [L // C_p // R] \ R_s$$

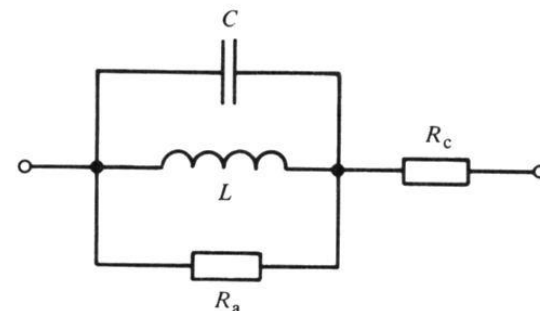

Fig. 11.25



L calculation

$L = 0.002 \cdot l \cdot (\ln(4l/d) - 0.75)$ (μH) for a group of parallel cables (diameter d , length l in cm)

$L = 0.004 \cdot l \cdot (\ln(2D/d) - D/l + 0.25)$ (μH) for 2 parallel cylindrical conductors (length l cm, diameter d , distance D , $D/l \ll 1$)

$L = 0.002 \cdot \ln(4h/d)$ ($\mu\text{H}/\text{cm}$) for one conductor (diameter d , height h above ground)

Empirical rule: 5 to 10 nH/cm

$M = 0.002 \cdot l \cdot (\ln(2l/d) - 1 + D/l)$ (μH) mutual inductance of 2 parallel straight conductors (length l , distance D , $D/l \ll 1$)

$M = 0.001 \cdot \ln(1 + (2h/D)^2)$ ($\mu\text{H}/\text{cm}$) mutual inductance of 2 parallel straight conductors (distance D , height h above ground)



L calculation – PCB track impedance

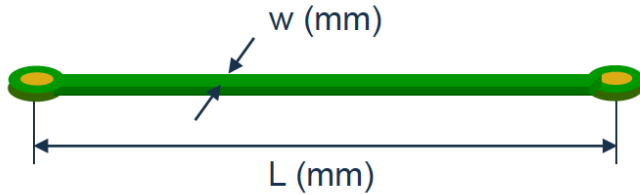

► Résistance ($e = 35 \mu\text{m}$)

- $R_{m\Omega} = \frac{0,5 \times L}{D}$

► Self

- $L \approx 10 \text{ nH / cm}$

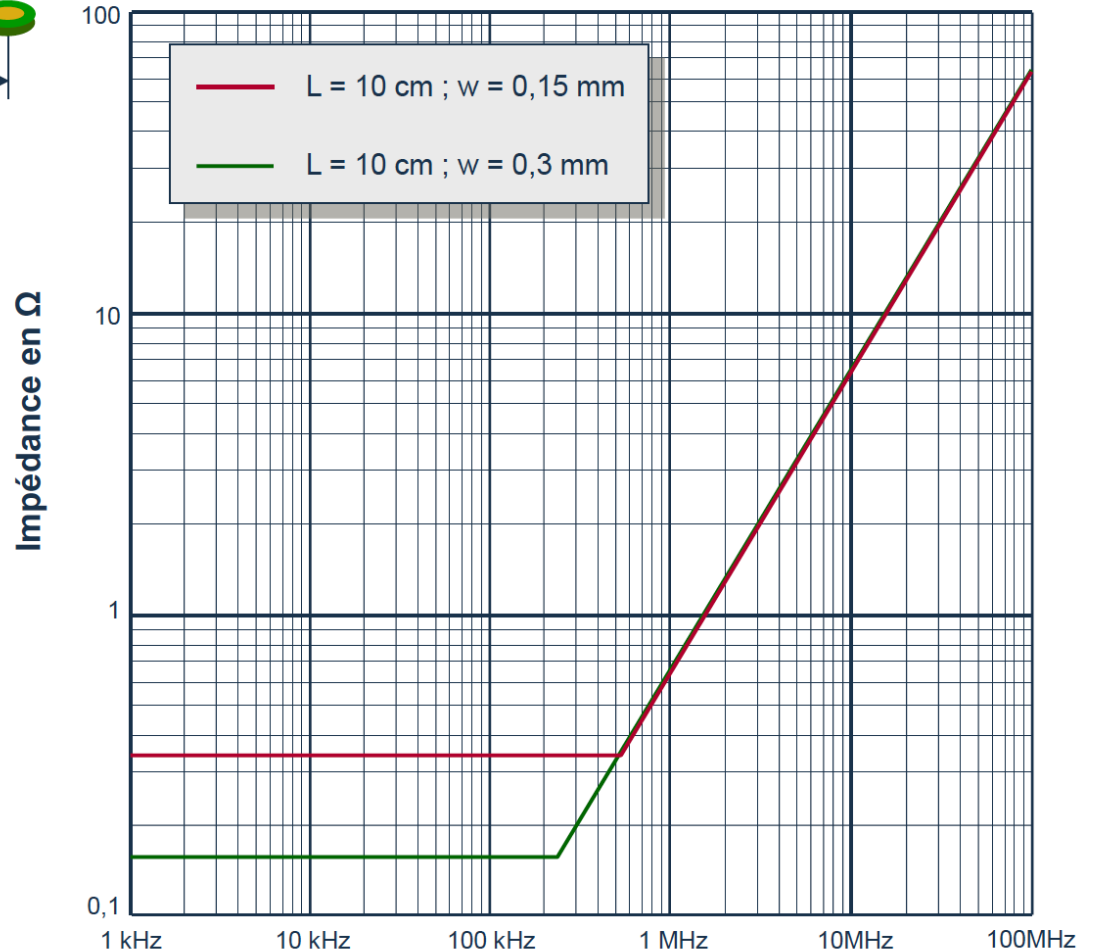



Basic passive components: L calculation

$$L_{A-B} = \mu_r \cdot \mu_0 (hl) / w$$

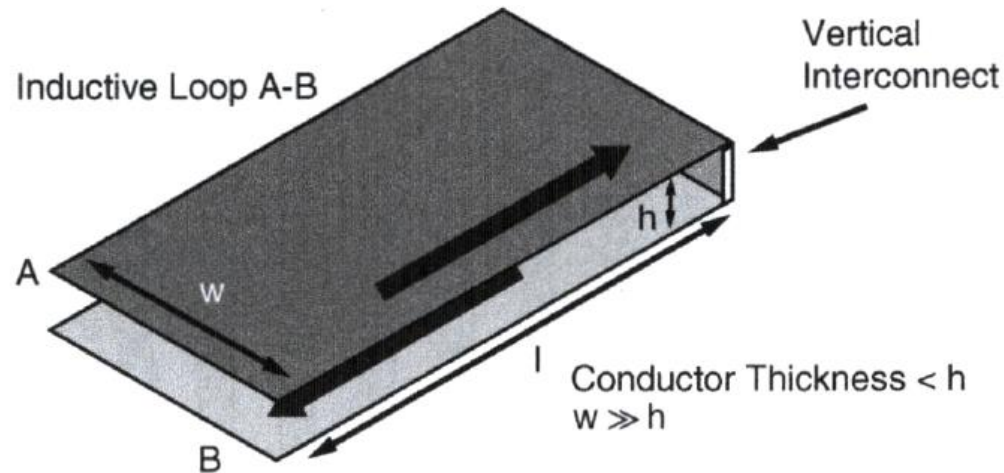
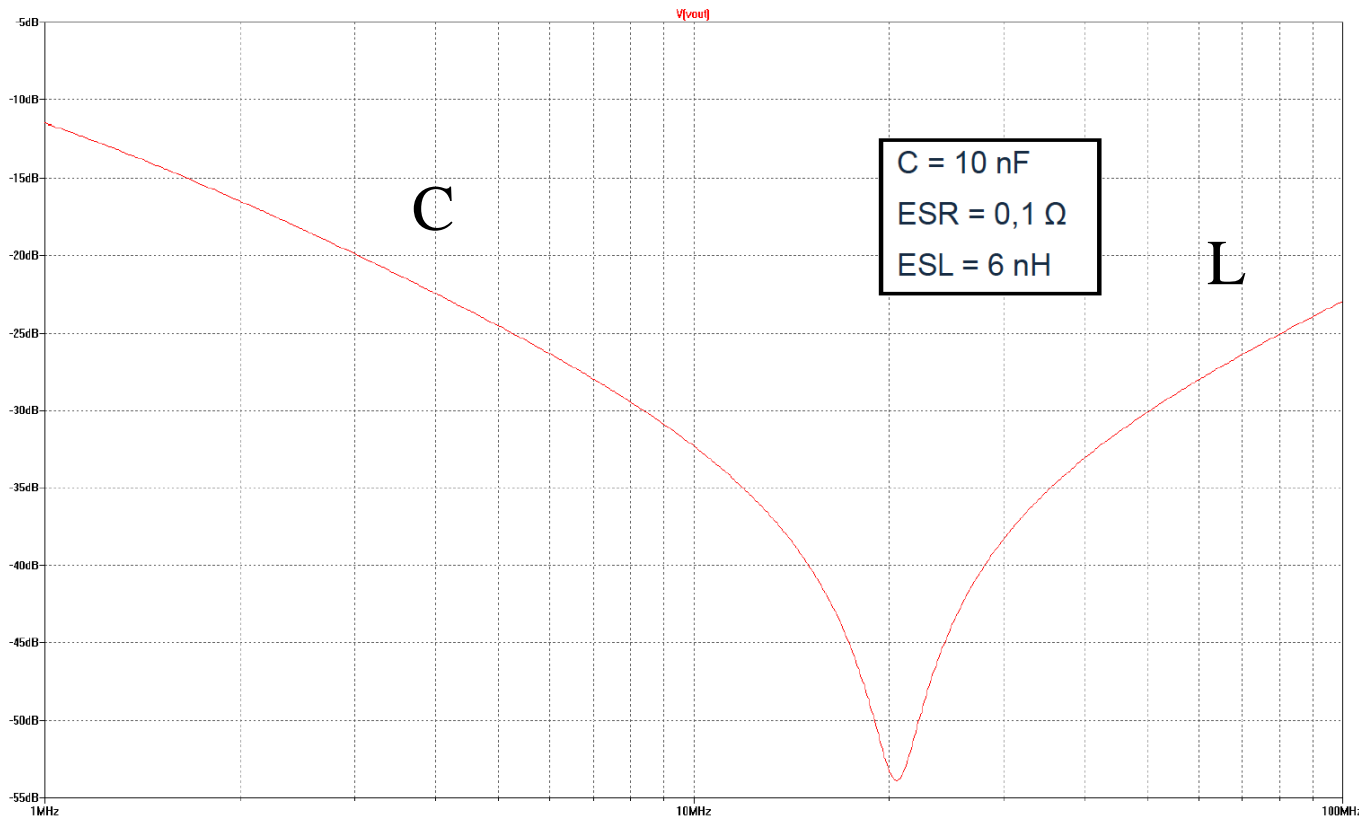
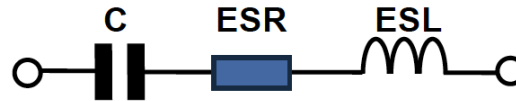

Figure 4.3 Theoretical parallel plate transmission line with end termination forming an inductive loop

Passive components vs. H.F.



$C(f)$, parasitic R for dielectric losses





C calculation

$C = 0.0885 \cdot A/d$ (pF) for two plate of A (cm²) separated by d (cm) (in vacuum)

$C = \pi \cdot 0.0885 / \cosh^{-1}(D/d)$ (pF/m) between 2 conductors (diameter d , distance D) (in vacuum)

0.0885 for ϵ_0 , multiply par ϵ_r for other materials.



C

Class X (ϕ - ϕ & ϕ -N - DM) and Y (ϕ -PE & N-PE - CM)

C (f)

- DC, LF : electrolytic, tantalum
- LF coupling (<1MHz) : MKT, MKC
- HF coupling : ceramic, mica
- HF decoupling : ceramic

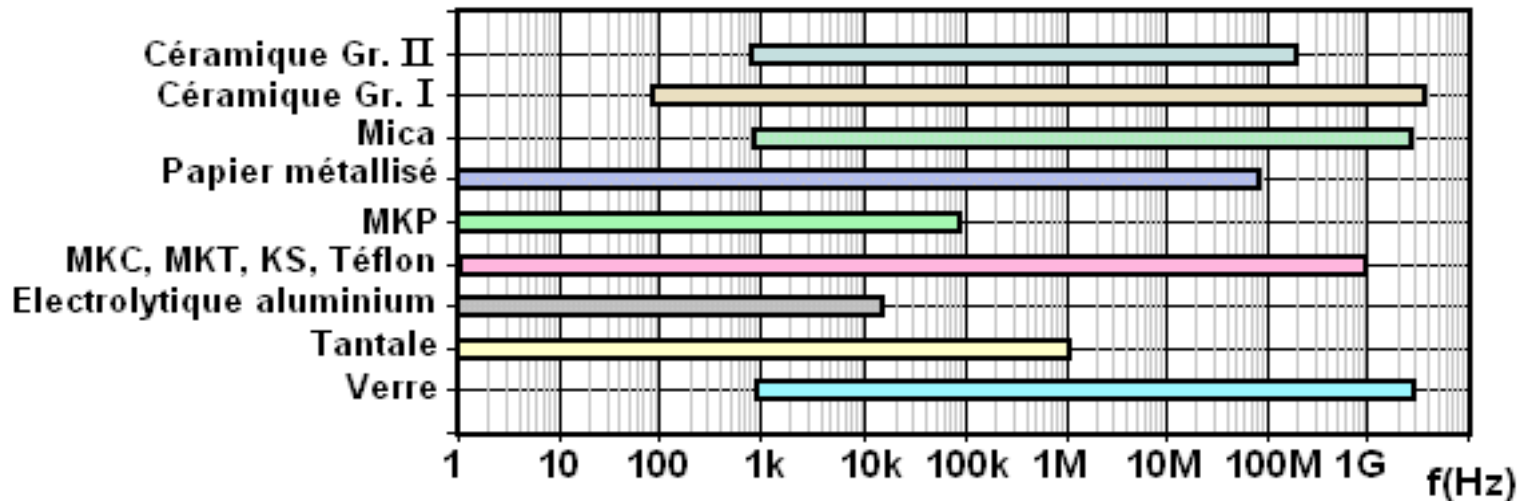

[Murata]

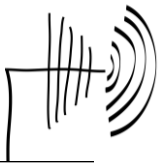

Passive components vs. H.F.

Capacitor Comparison – Reference

Type	Advantage	Disadvantage
Ceramic Class 1	Small Size, Inexpensive, Stability, Range Of Values, Low L, Very Low ESR	Small Values (10 nF)
Ceramic Class 2	Low L, Range Of Values	Poor Stability, HV Coefficient
Polypropylene	Inexpensive, Range Of Values, Low ESR, Low Leakage	Damaged > +105° C, Large, High L
Teflon	Stability, > +125° C, Range Of Values, Low ESR, Low Leakage	Expensive, Large, High L
Polycarbonate	Stability, Low Cost, Temperature Range, Low ESR, Low Leakage	Large, High L
Mica	Low Loss At HF (low ESR), Low L, Very Stable, < 1%	Large, Low Values (<10 nF), Expensive
Aluminum Electrolytic	Large Values, High Currents, High Voltages, Small Size	High Leakage, Polarized, Poor Stability & Accuracy, High L
Tantalum Electrolytic	Small Size, Large Values, Low ESR, Medium L	High Leakage, Polarized, Expensive, Poor Stability & Accuracy

© 2008 Linear Technology



https://en.wikipedia.org/wiki/Ceramic_capacitor



- **conducted**
- radiated

performance measurement?

= decreasing of disturbance (U, I, P)

= **Insertion Loss I.L.**

$$= \frac{\text{amplitude of disturbance **without** component}}{\text{amplitude of disturbance **with** component}}$$

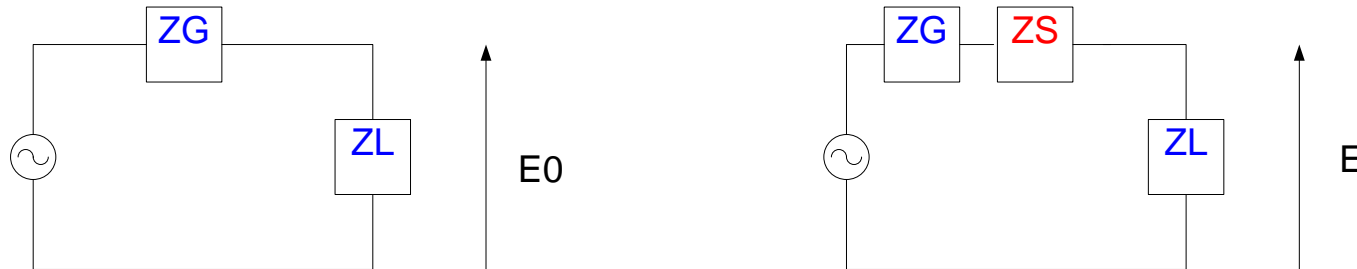

$$Att = 20 \log_{10} \left(\frac{E0}{E} \right) = 20 \log_{10} \frac{|ZG + ZL + ZS|}{|ZG + ZL|}$$

Conducted



- some components are bidirectionnal (EMI / EMS)
- importance of source and load impedances (see previous equation)
- take into account the type of ports (power / signal)
- CM / DM or both
- ...



Filters

- to decrease disturbances from EUT to mains
- to decrease disturbances from mains to EUT

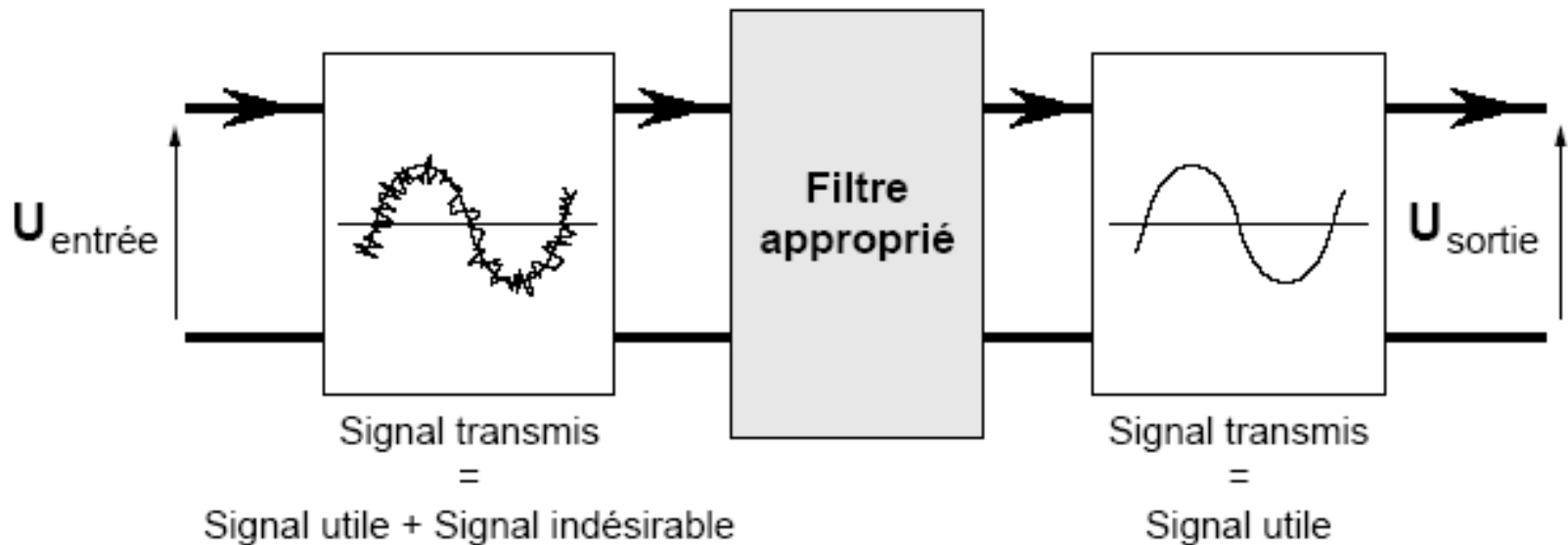

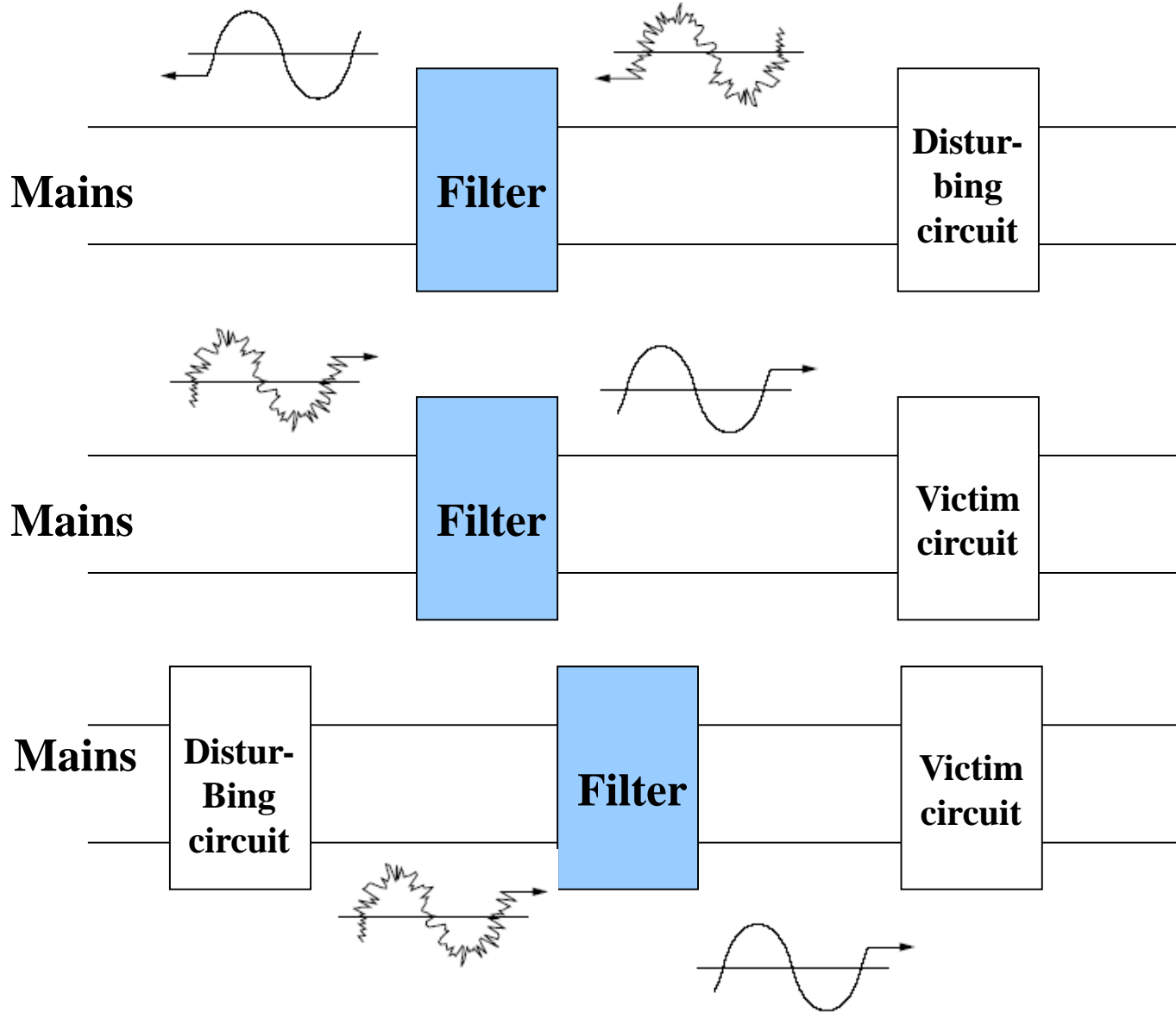



Conducted - Power Lines

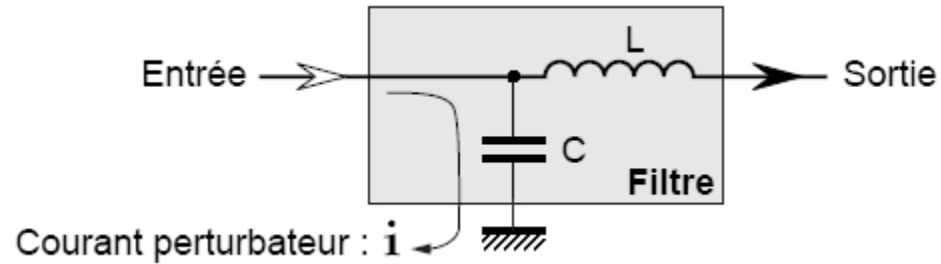



Efficient low-pass filter:

$$C \longleftrightarrow Z_s \text{ ou } Z_L \gg$$

$$L \longleftrightarrow Z_s \text{ ou } Z_L \ll$$

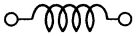
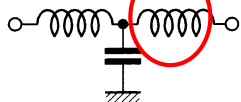
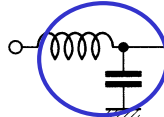
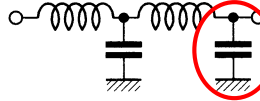
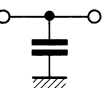

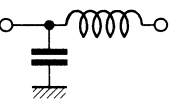
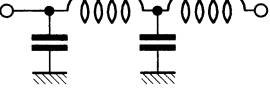
Z_{source}	Configuration du filtre	Z_{charge}
Faible	$n = 1$ (20 dB / décade)  $n = 3$ (60 dB / décade) 	Faible
Faible	$n = 2$ (40 dB / décade)  $n = 4$ (80 dB / décade) 	Élevée
Élevée	$n = 1$ (20 dB / décade)  $n = 3$ (60 dB / décade) 	Élevée
Élevée	$n = 2$ (40 dB / décade)  $n = 4$ (80 dB / décade) 	Faible

Ideal model
(no parasitic components)

ⓘ Data sheet
For $Z = 50\Omega$

Conducted - Power Lines



Le filtrage passif «en mode différentiel»

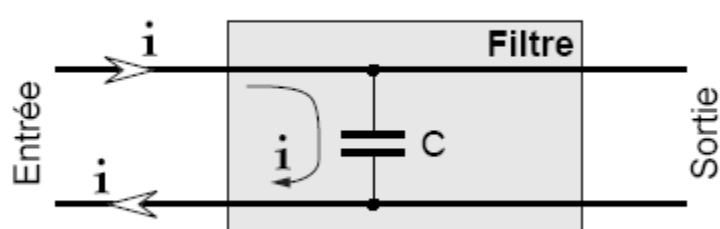

Courant perturbateur de mode différentiel

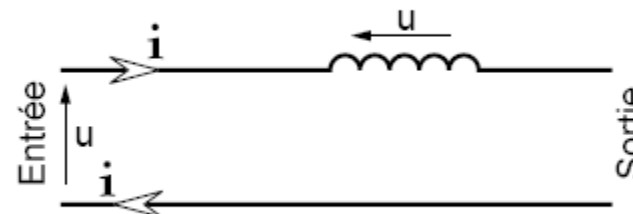

Le filtrage passif «en mode commun»

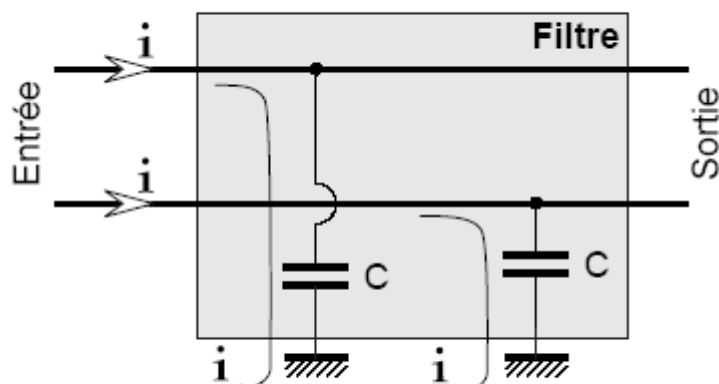

Courant perturbateur de mode commun

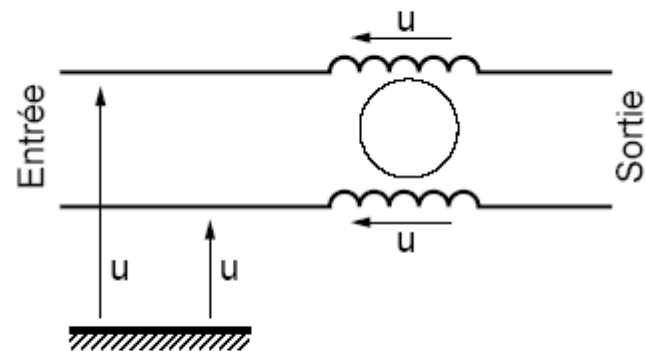

En mode différentiel, les 2 selfs s'annulent car elles sont bobinées en sens inverse sur le même noyau.



Conducted - Power Lines

A correct implementation is mandatory

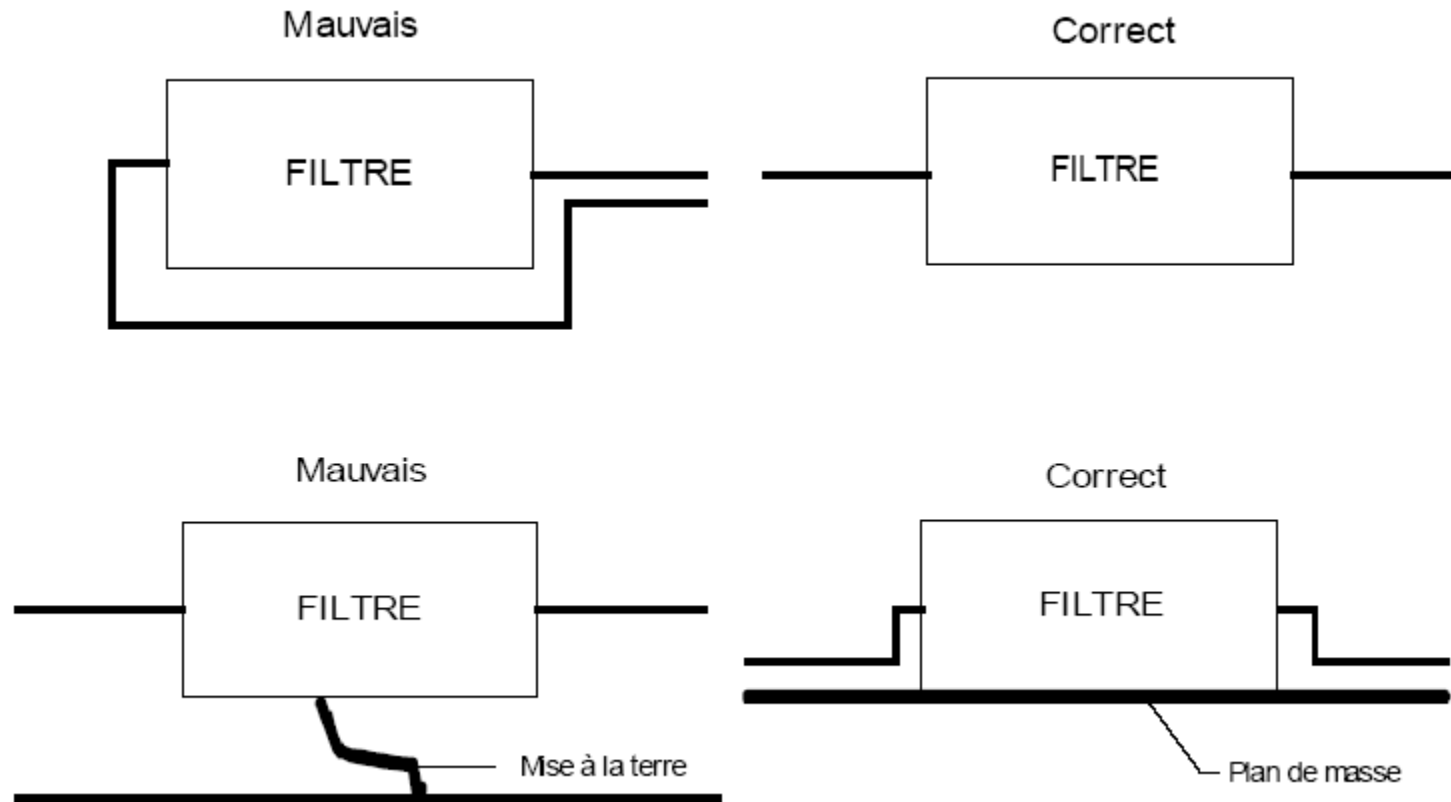

[EN 50174-2]



Conducted - Power Lines

EFFET D'UN MONTAGE INCORRECT, EN L'AIR

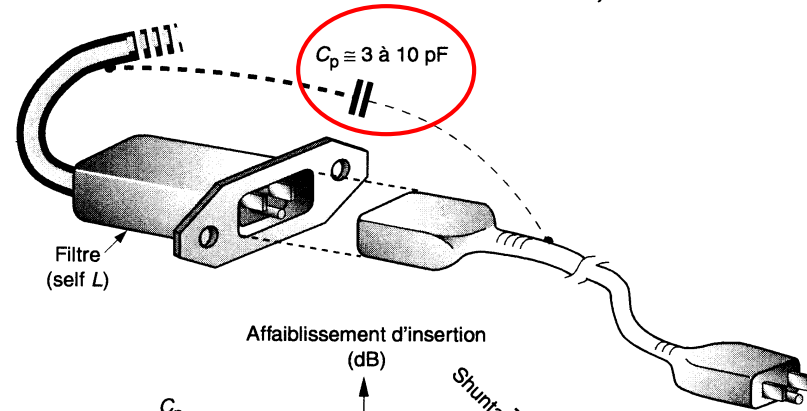

A correct implementation is mandatory

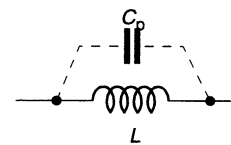

Ex. : pour $L = 3 \text{ mH}$
et $C_p = 3 \text{ pF}$,
 $F_{\text{res}} = 16,8 \text{ MHz}$

Affaiblissement d'insertion (dB)

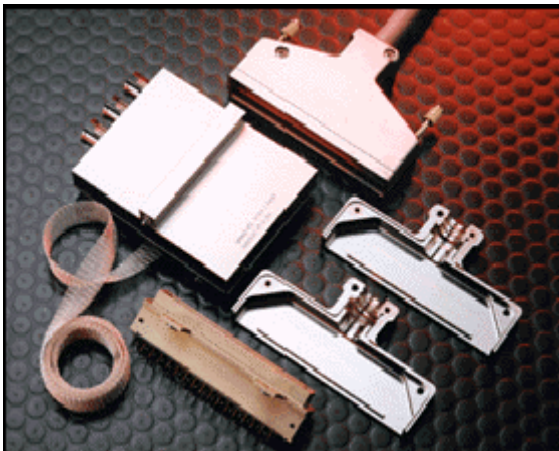
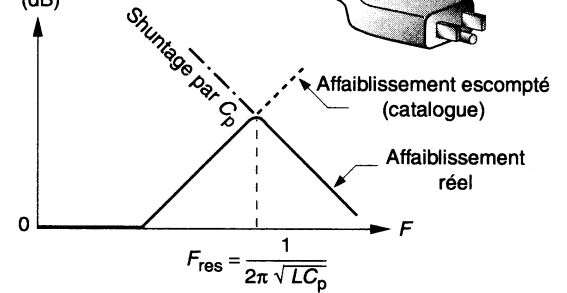

AMÉLIORATION GRACE À UN MONTAGE CORRECT

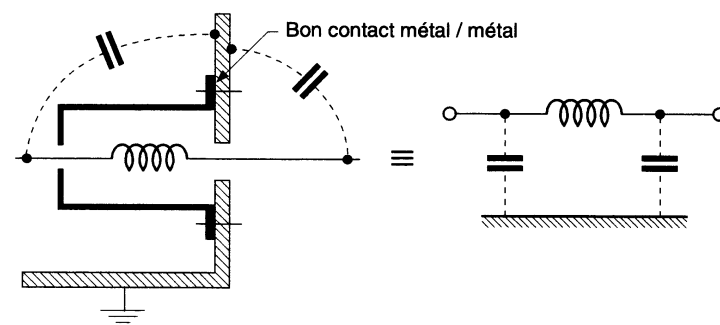



Conducted - Power Lines

Isolation transformers

- to allow changing earthing system (IT, TN...)
- to insure a good galvanic isolation in LF

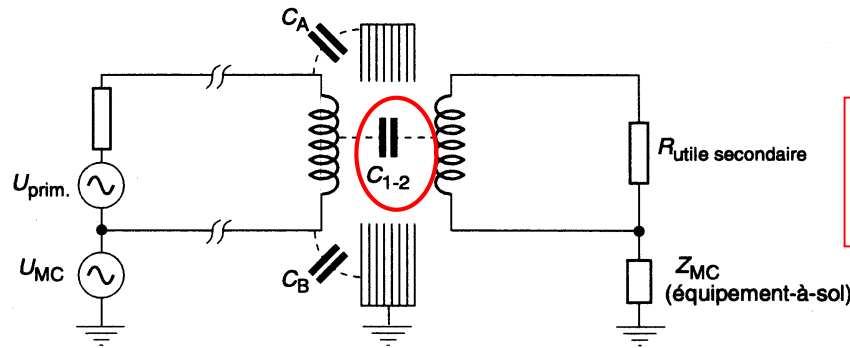

$C_{12} = 50 \text{ pF}$ for 100VA
some nF for some kVA

Transformateur ordinaire

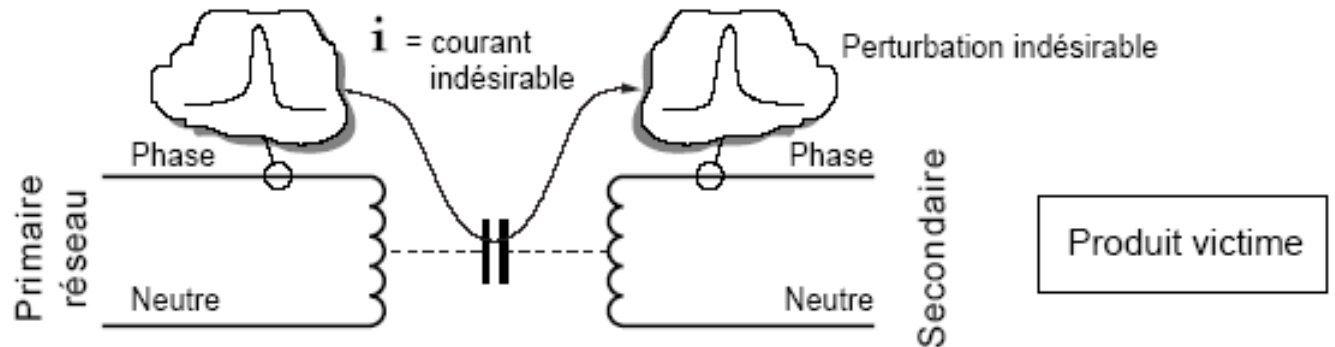



Conducted - Power Lines

Isolation transformers

Transformateur	Représentation	Isolement	
		BF	HF
Standard	<p>Primaire Secondaire</p>	OK	Inefficace
Simple écran	<p>Primaire Secondaire</p>	OK	Moyen
Double écran	<p>Primaire Écran de mode commun TN-S Neutre PE</p>	OK	Bien

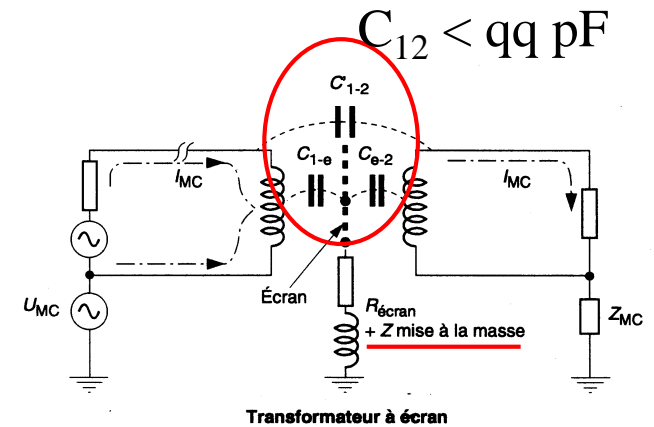



Conducted - Power Lines

Isolation transformers

A correct implementation is mandatory

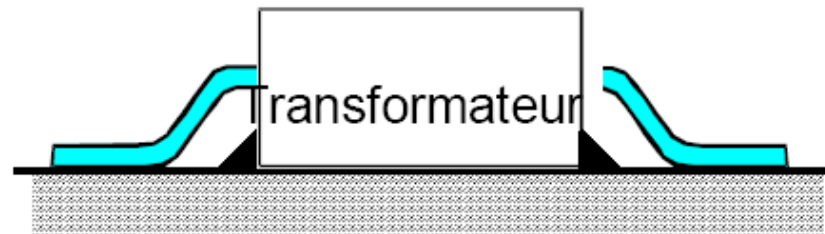
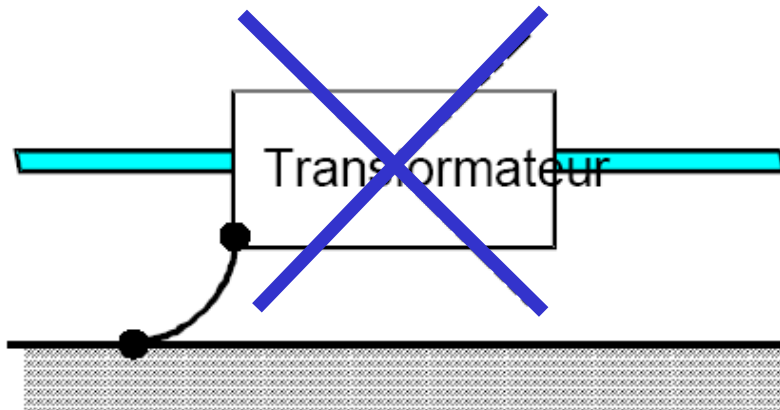
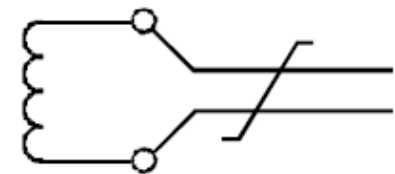
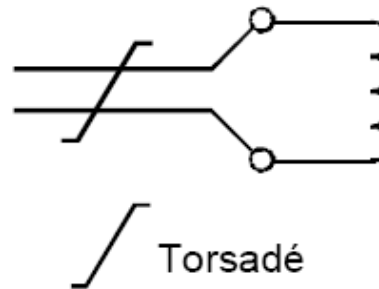
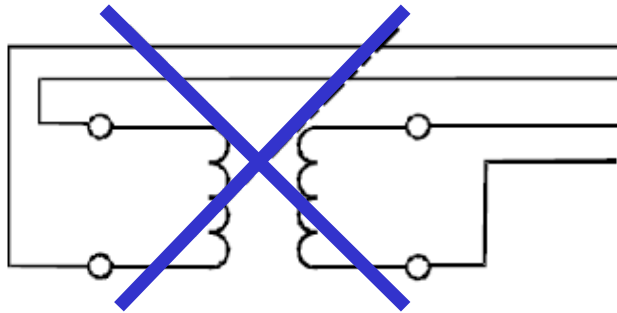

[EN 50174-2]



Conducted - Power Lines

Components for transients

Different kinds of components are used for the protection against overvoltages.

1. Spark gap (“*éclateurs*”)
2. Varistors
3. Semi-conductor components



Conducted - Power Lines

Components for transients

Ideal protection criteria?

In the presence of a disturbance, the ideal protection component should limit immediately the voltage to a level lower than the lower value of the maximum acceptable voltage for the circuit.

Regarding consumption, it should consume:

- The minimum of energy during permanent regime
- The maximum of energy during disturbance

Protections in series or in parallel: check the defect mode of the component (open circuit or short circuit).



Components for transients

Spark gap

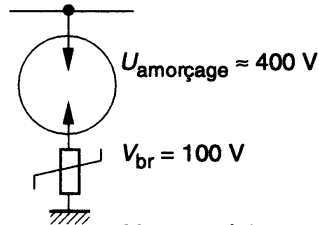
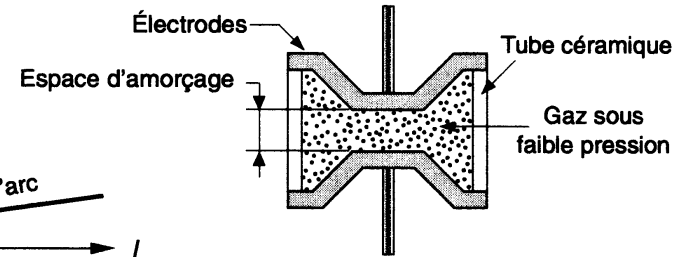
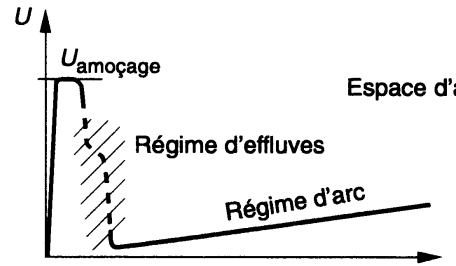
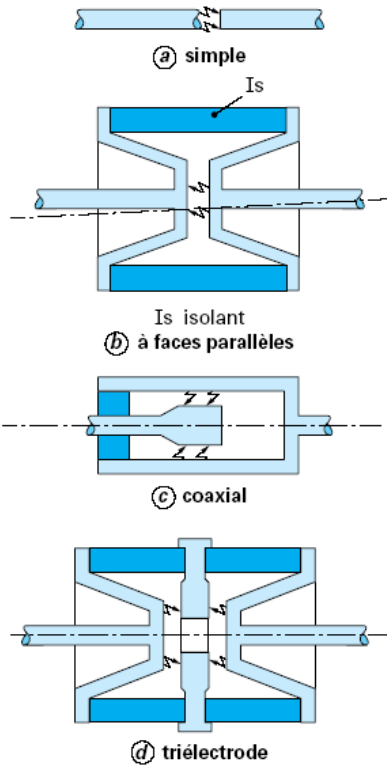

Montage évitant le courant de suite : en fin de perturbation, la tension V_{dr} de la varistance empêche le maintien de l'arc.

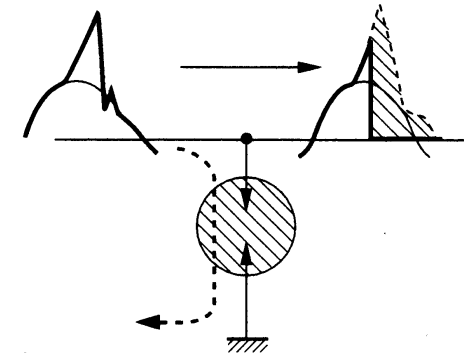



Components for transients

Spark gap

Main characteristics:

- Very low residual voltage (+)
- Very low parasitic capacitor (+)
- Very high flowing capacity (+)
- Sparking time is related to gas ionisation (-)

Criteria:

- sparking voltage $>$ maximum voltage of circuit (x 1.5)
- maximum sparking current $<$ destruction value
- lifetime



Components for transients

Varistors (*varistances*)

This is a component with a resistance varying according to the reverse of applied voltage

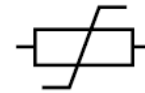

$$J = KV^\alpha$$

Varistors ZnO prepared by sintering (*frittage*) of different oxides (chemical mixture and thermal treatment are very important).

Criteria:

- Calculation of dissipation energy
- Stability of characteristics (dc, ac and pulse)

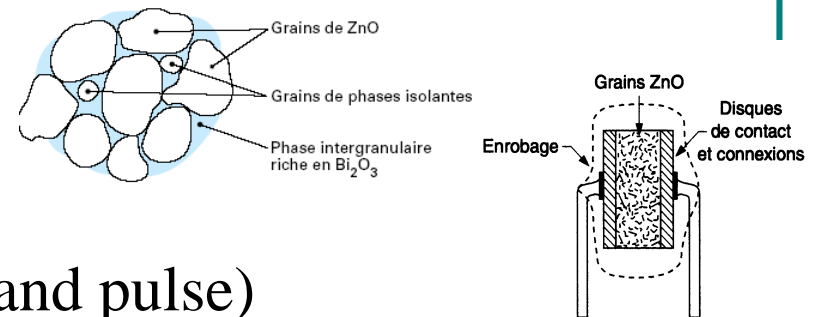



Components for transients

Varistors (*varistances*)

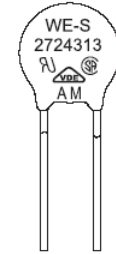
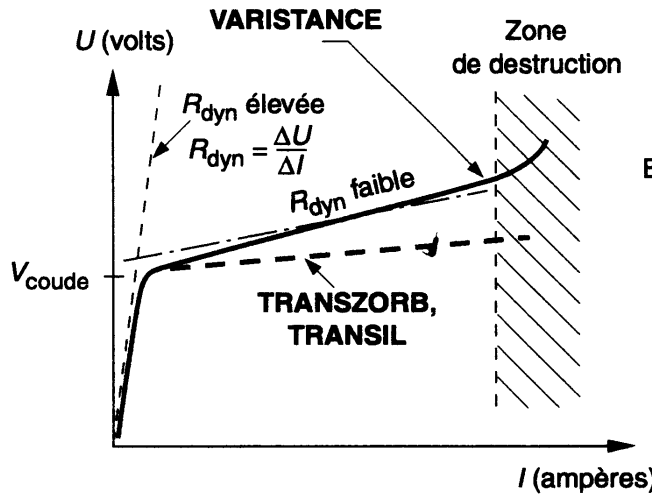

Advantages:

- moderate cost
- small response time (< 50 ns)
- different values of knee voltage available.

Drawbacks:

- slope I-U is soft
- high parasitic capacitor
(not efficient for quick signals)
- slow destruction by fatigue, carbonisation risk and burst

Components for transients



Semi-conductors

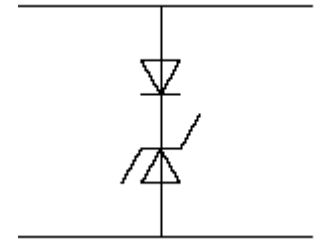

- diodes inversely polarised (Zener and avalanche)
- thyristor effect component
- « surge suppressor » group of components, integrated on the silicium level.

Characteristics:

Easy to use (+), economic (+), very quick (+), nearly perfect characteristics (+), steady voltage in conduction regime (+), limited absorption energy capacity (-), end of life as short-circuit (-).



Dispositif	Tension de service du circuit protégé (V)	Temps de réponse (ns)	Possibilité d'absorption d'énergie (J)	Capacité (pF)	Courant de fuite au repos (A)	Gamme de température d'utilisation (°C)
Diode en direct (§ 2.1)	0,5 à 10	très rapide < 1	faible 10^{-2} à 1	faible 10 à 100	important 10^{-6} à 10^{-3}	- 40 à + 85
Diodes Zener et à avalanche (§ 2.2.2)	5 à 200	très rapide < 0,1	faible 10^{-2} à 1	élevée 10^3 à 10^4	important 10^{-6} à 10^{-3}	- 65 à + 125
Dispositif à effet thyristor (§ 2.3)	75 à 300	10 à 50 (fonction de dv/dt)	bonne quelques joules	moyenne 10 à 300	faible 10^{-5}	limitée - 40 à + 85
Varistances (ZnO) (§ 3.3)	5,5 à 5 000	≤ 1	très bonne 10 à 10^4	moyenne 10^2 à $5 \cdot 10^3$	faible 10^{-7} à 10^{-6}	- 55 à + 125 (modèles standards) - 55 à + 85 (modèles de forte puissance) (limitation à haute température due au courant de fuite)
Éclateurs à gaz (§ 5)	100 à 20 000	< 1	très bonne 10^2 à 10^4	très faible 1 à 10	très faible 10^{-12} à 10^{-9}	- 55 à + 125

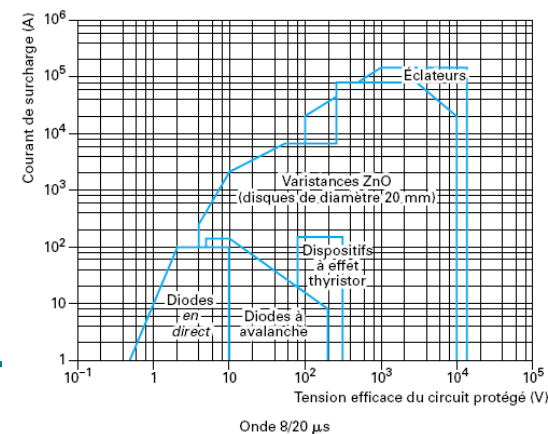

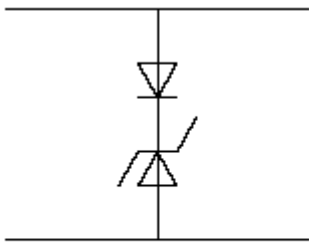

(a) montage unidirectionnel

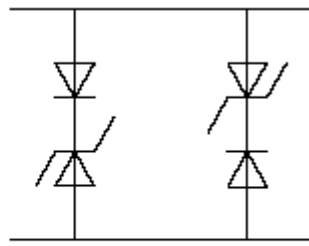

(b) montage bidirectionnel

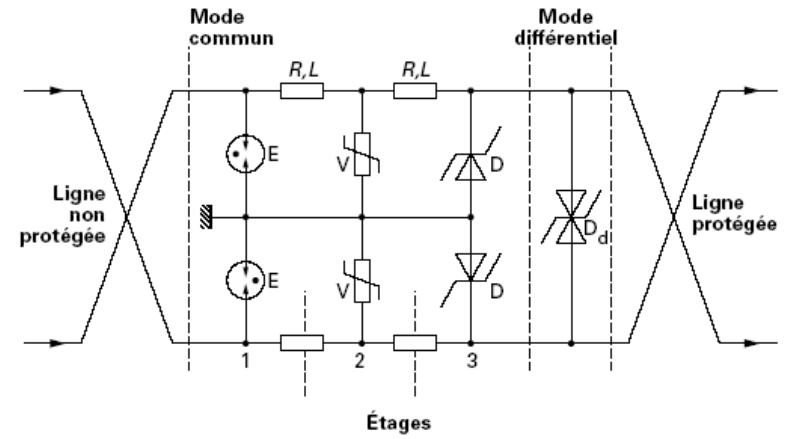
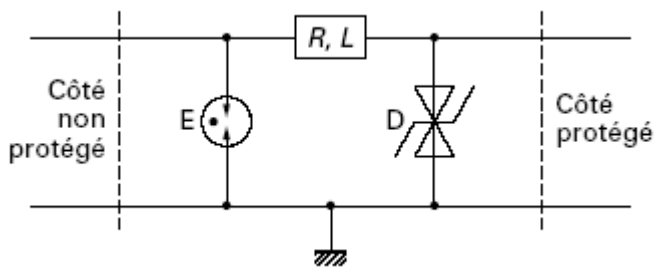
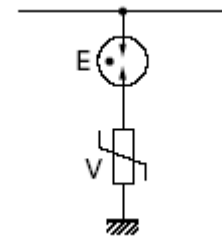

- D diodes de protection
- D_d diode bidirectionnelle
- E éclateurs
- V varistances

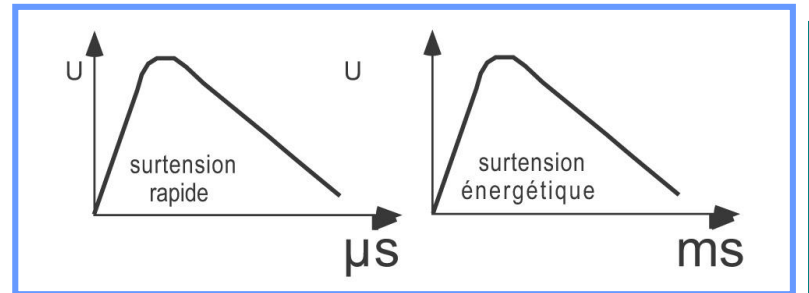

Gas tube

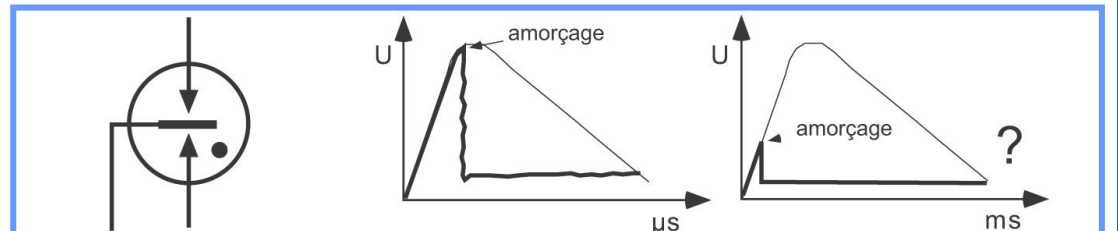

Varistor

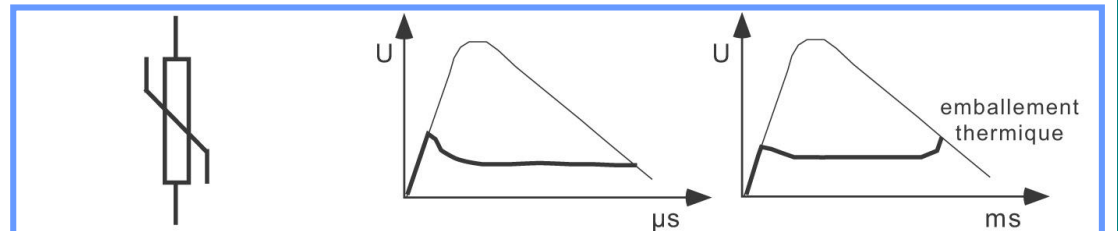

Semi-conductor

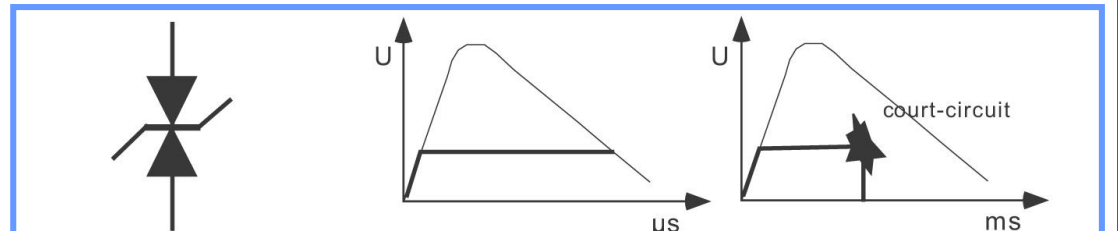

Components for transients



- In EMC efficient components are mandatory but a good implementation is also mandatory.
- Those components are efficient regarding transients, but fuses and breakers are still mandatory on the input of power circuits.
- To install components as near as possible.
- Energy to ground.
- In case of components in parallel, take care of their non linearity.
- Importance of **equipotentiality**.



Conducted - Signal lines

Filters for signals

C = écoulement des courants de MC à la masse-châssis

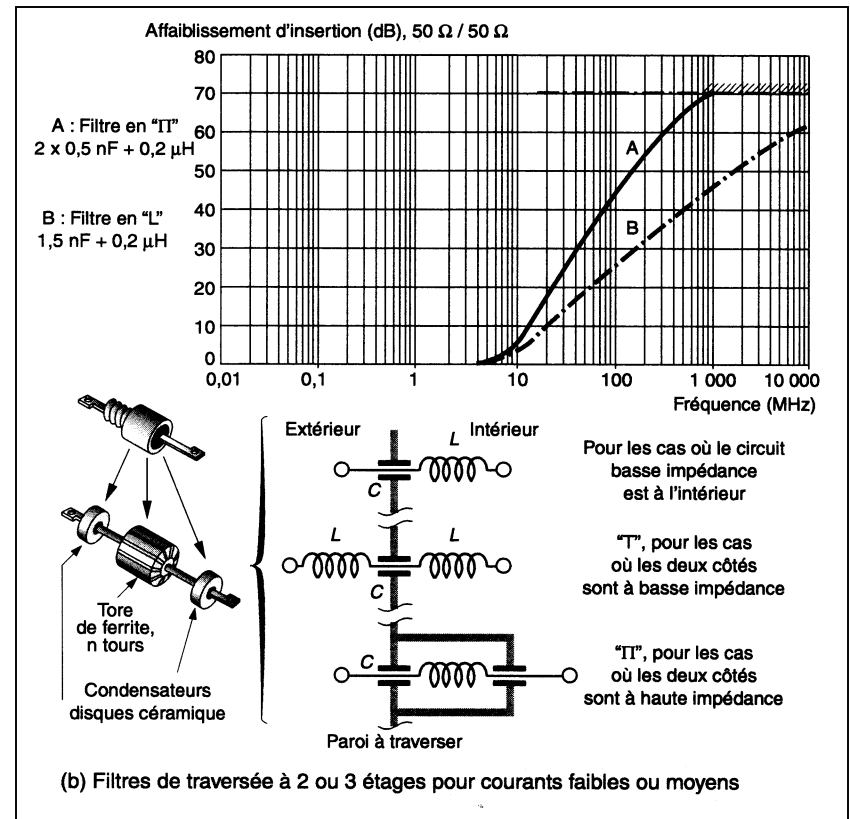
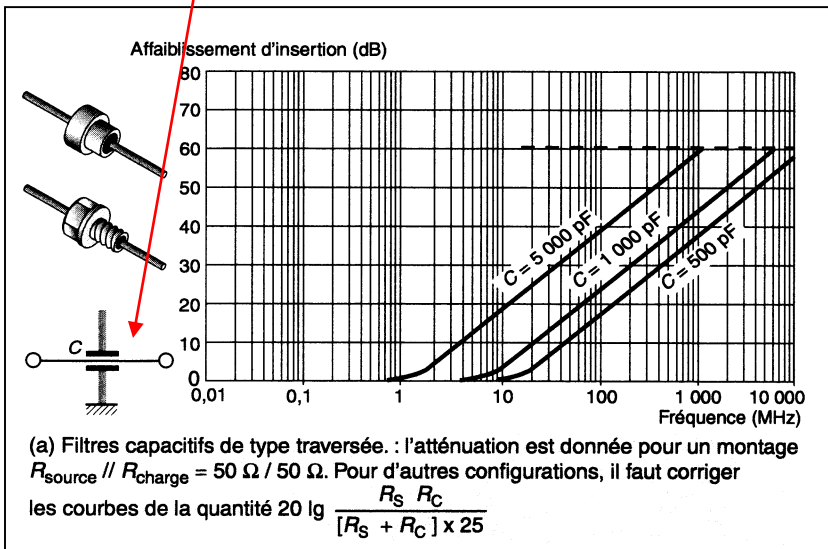

Individual filtering for signal lines



Conducted - Signal lines

Filters for signals

parasitic L

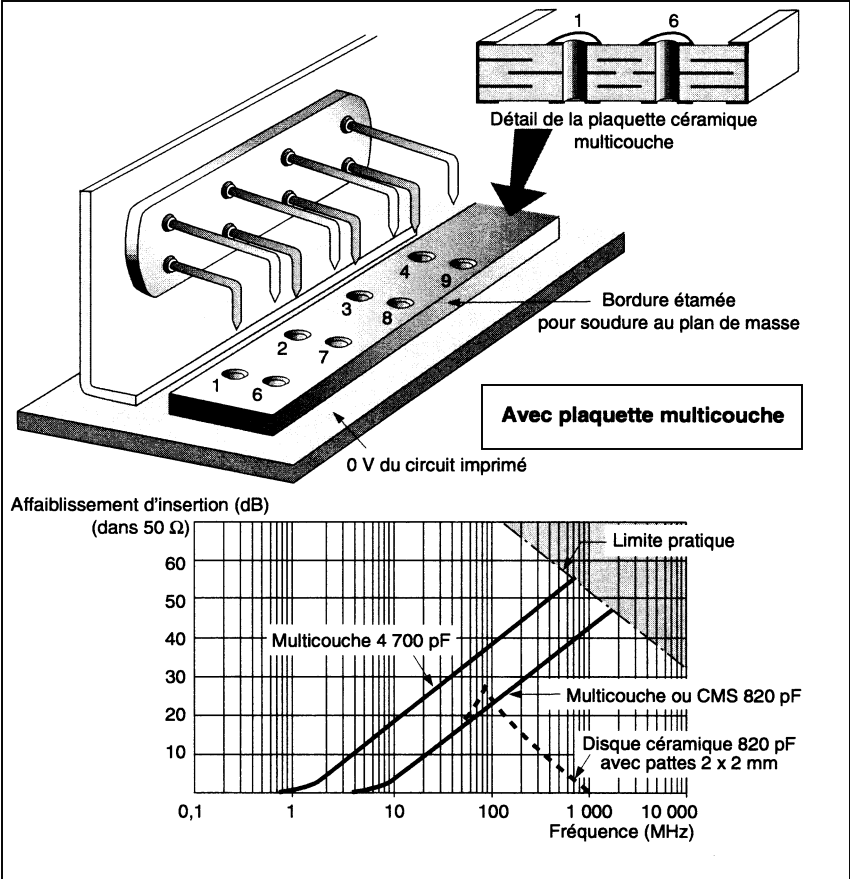
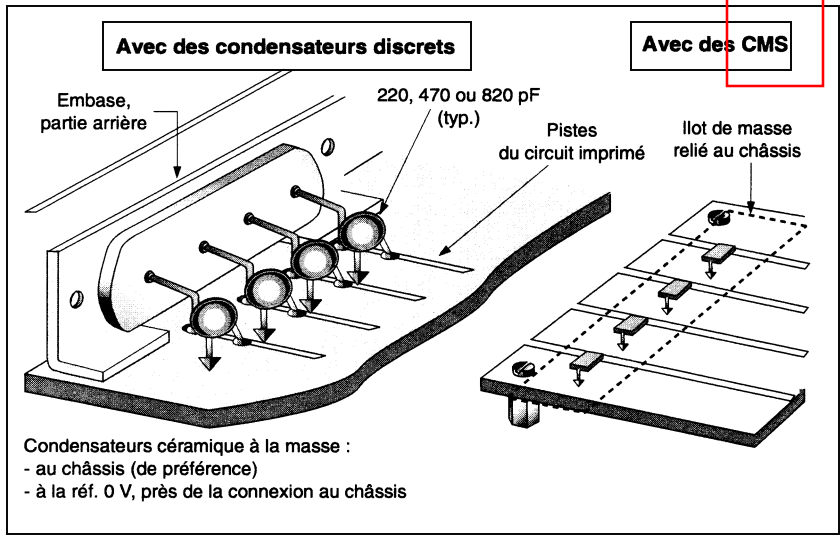

Filter I/O on printed circuit board



Conducted - Signal lines

Filters for signals

PA4 = 400 pF min
 P02 = 1 800 pF min
 P04 = 4 000 pF min
 P08 = 8 000 pF min
 P16 = 16 000 pF min

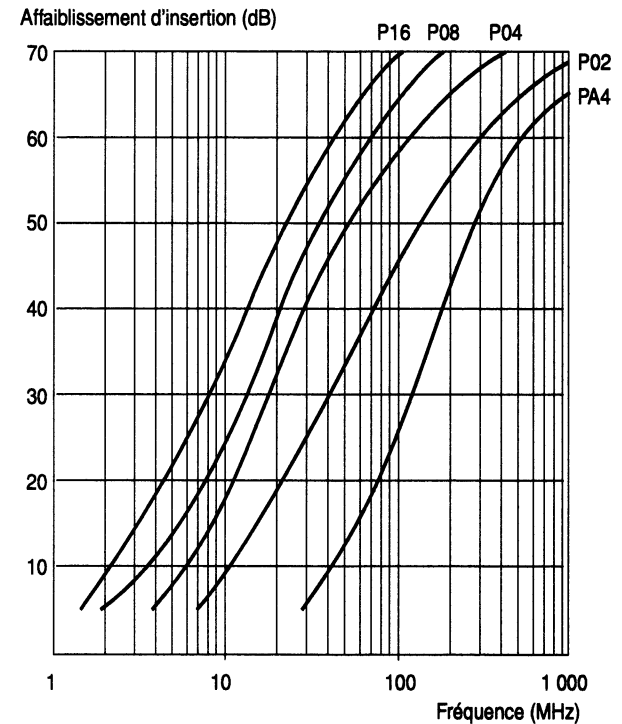
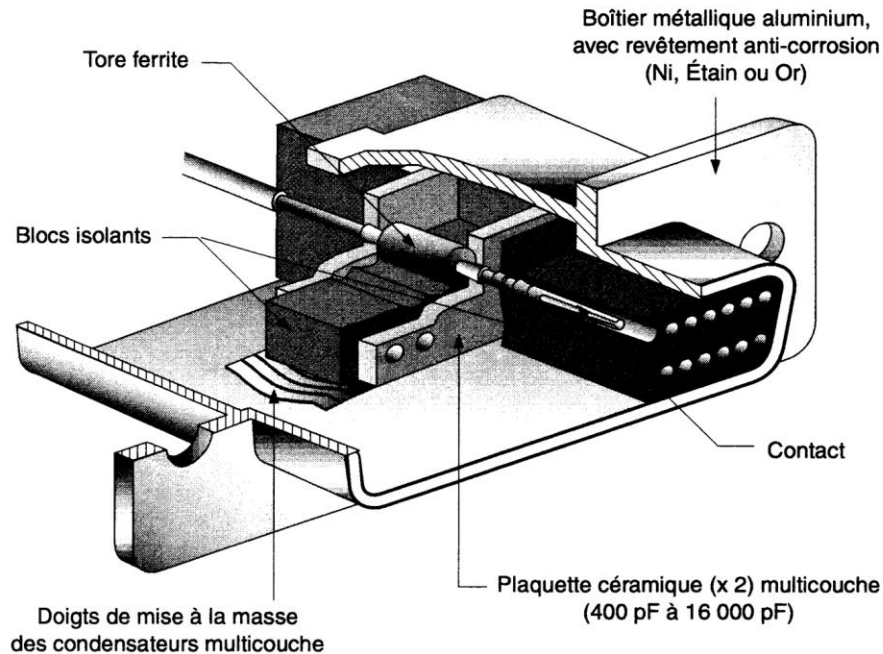

Connector-filter in Pi [Amphenol®]



Conducted - Signal lines

Isolation transformers for signals DM (transmitted) - CM (blocked)

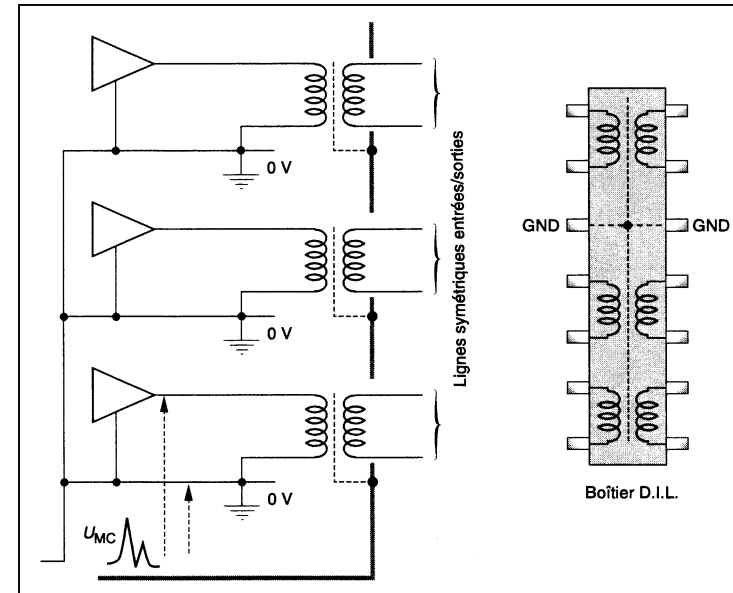
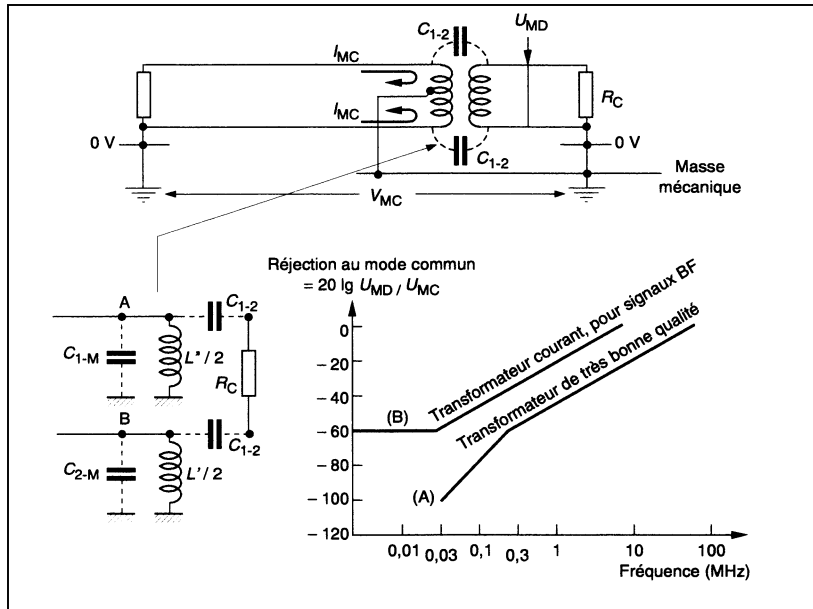

With mid-point:

- I_{MC} : OK
- galvanic insulation of ground: KO

With screen for signal bus

Conducted - Signal lines

Optical couplers

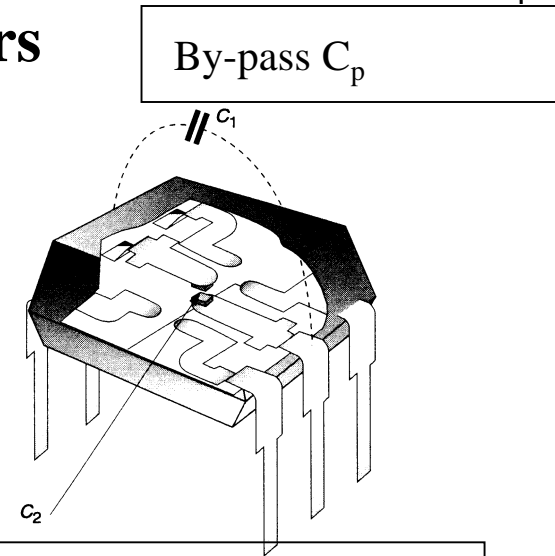

Internal C_p (between LED and photosensitive element)

L'opto-coupleur

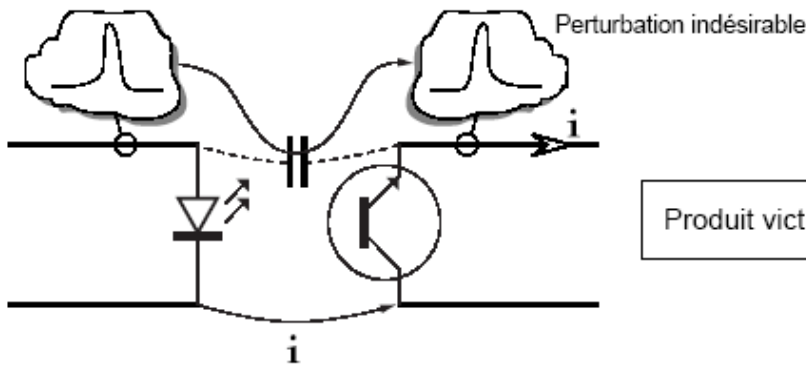

Produit victime



Conducted - Signal lines

Optical couplers

Importance of a correct implementation

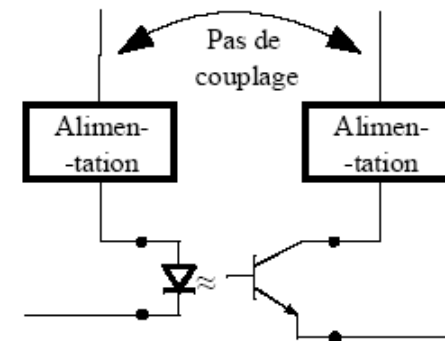
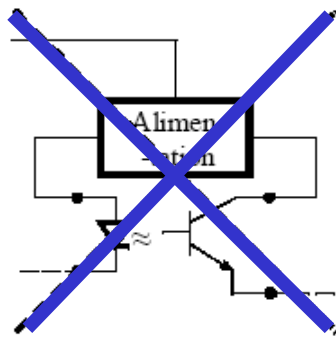
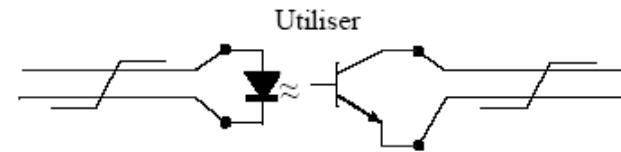
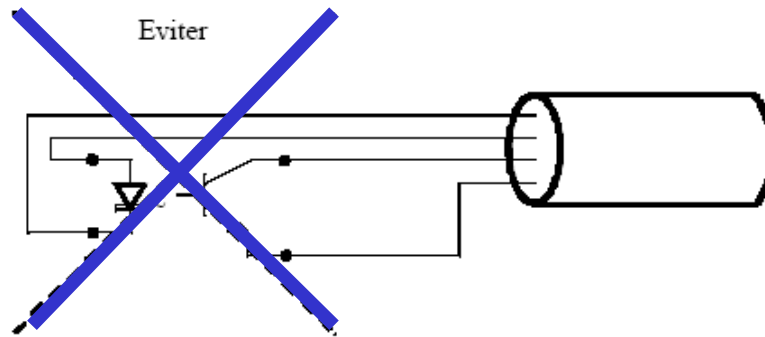

[EN 50174-2]



Power / signal lines

Baluns – CM inductances

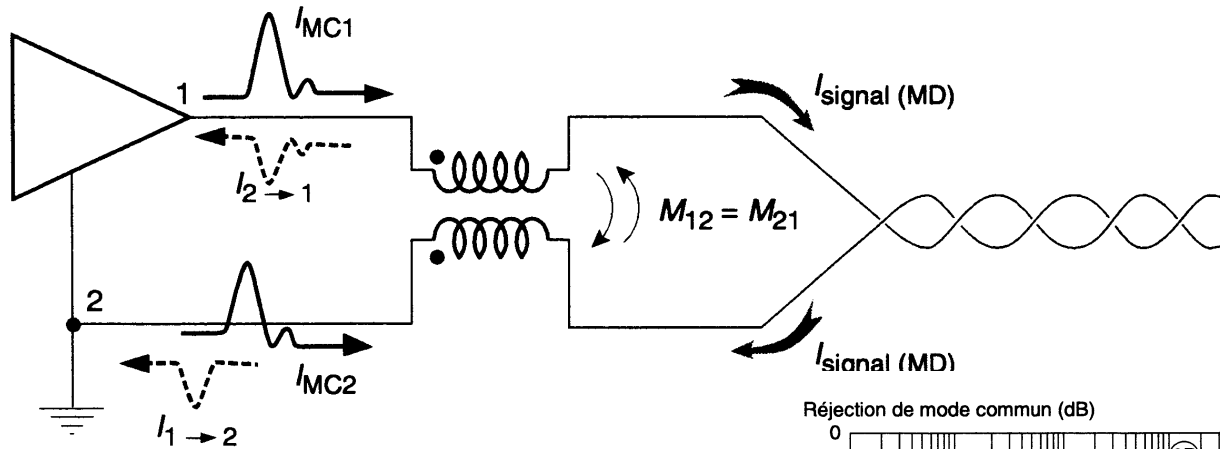

Réjection de mode commun (dB)

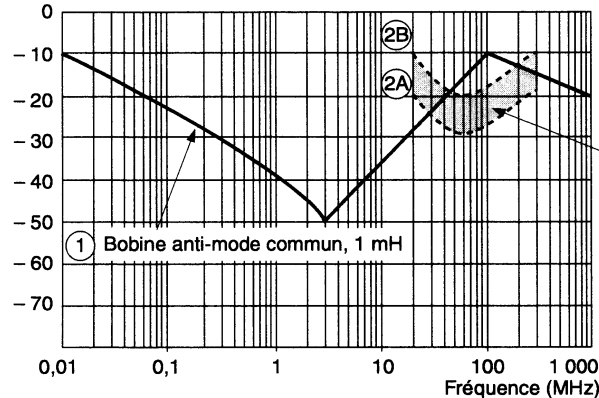

Boîtier D.I.L.

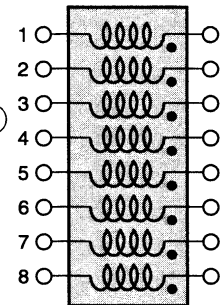

① Transformateur "Balun" pour applications BF.

② Transformateur anti-mode commun pour liaisons numériques 8 fils.

La courbe 2B correspond au plus mauvais cas : signal aller broche n° 1, retour broche n° 8.

La courbe 2A correspond au meilleur des cas : aller en n° 1, retour en n° 2.

La perte pour le signal utile est < 2 dB.



Power / signal lines

Ferrites (magnetic ceramic MFe_2O_4)

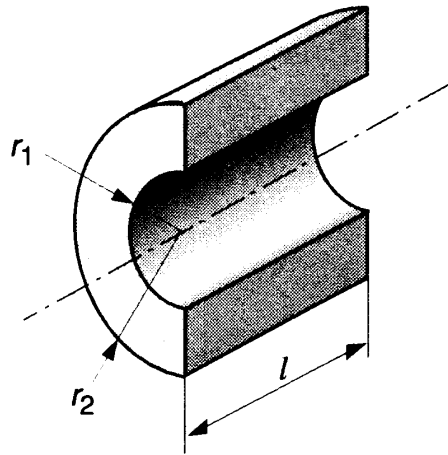

Flux dans le circuit magnétique : $\Phi_T = B \times l (r_2 - r_1)$

$$I_{\text{max (saturation)}} = \frac{B_{\text{max}} l (r_2 - r_1)}{L_{\text{ferrite}}}$$

$B_{\text{max}} = 0,1 \text{ à } 0,2 \text{ tesla (typ.)}$

- Nickel
- Manganese
- Zinc
- Copper
- ...

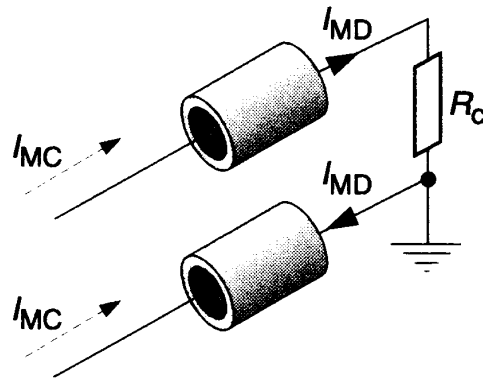

Un ferrite par fil atténue les courants MD **et** MC

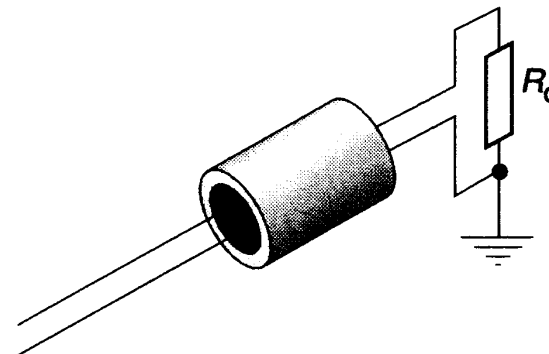

Un ferrite sur les 2 (ou 2 x n) fils n'affecte que I_{MC}



Power / signal lines

Ferrites

Nickel-Zinc (NiZn) :

- low permeability
- high resistivity
- usable frequencies $>10\text{MHz}$ & $<1\text{GHz}$

Manganese-Zinc (MnZn) :

- high permeability
- low resistivity
- usable frequencies $<10\text{MHz}$

Type	Material	μ_i	B_{sat} (mT)	T_c (°C)	ρ (Ωm)
Manganese Zinc	3E8	18000	350	100	0.1
	3E7	15000	400	130	0.1
	3E6	12000	400	130	0.1
	3E5	10000	400	120	0.5
	3E26	7000	450	155	0.5
	3E27	6000	400	150	0.5
	3C11	4300	400	125	1
	3S1	4000	400	125	1
	3C90	2300	450	220	5
	3S4	1700	350	110	10^3
	3B1	900	400	150	0.2
	3S3	250	350	200	10^4
	Nickel Zinc	4A15	1200	350	125
4S2		700	350	125	10^5
4B1		250	350	250	10^5
4C65		125	350	350	10^5
Iron Powder	2P90	90	1600	140 *	low



Power / signal lines

Ferrites

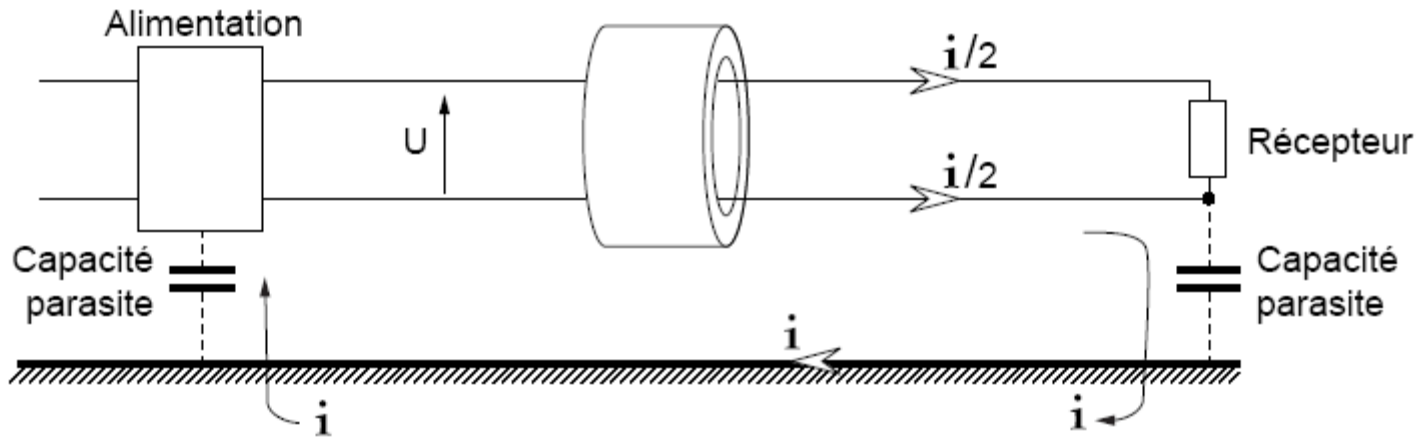



Power / signal lines

Ferrites

Equivalent circuit

$$Z = j\omega L_S + R_S = j\omega L_0 (\mu'_S - j\mu''_S)$$

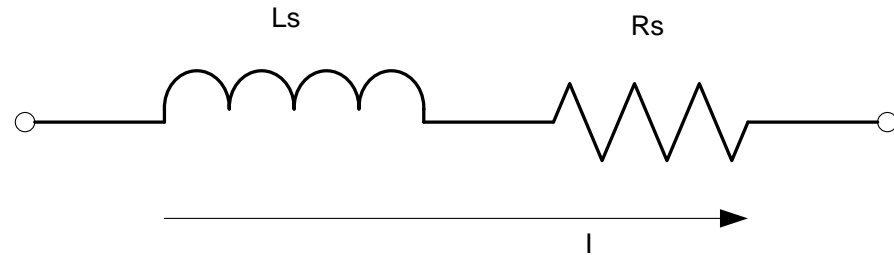

with

$$\omega L_S = \omega L_0 \mu'_S$$

$$LR_S = \omega L_0 \mu''_S$$

$$L_0 = \frac{4\pi N^2 10^{-9}}{C_1}$$

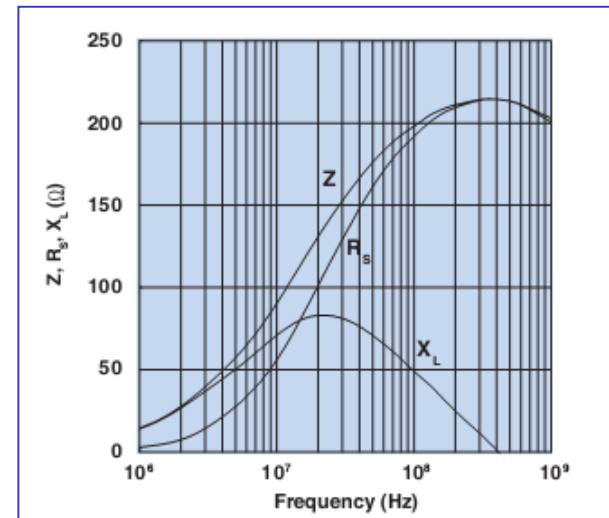
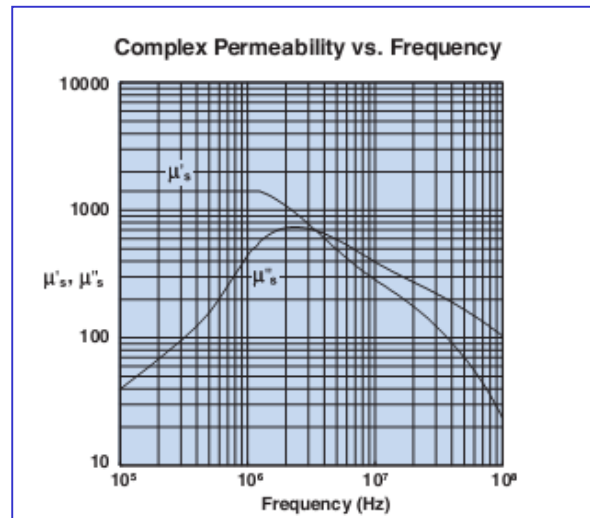



Power / signal lines

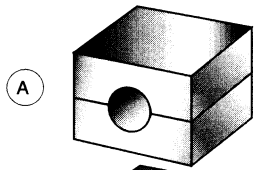
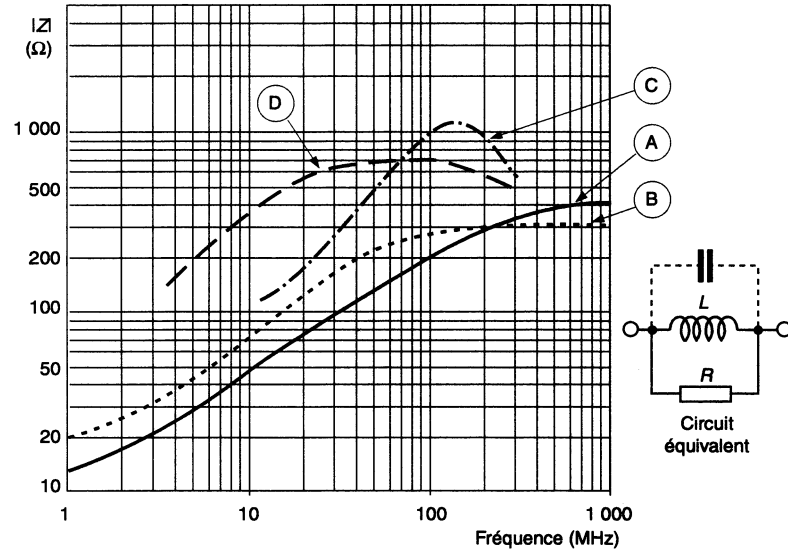

A Tore pour câble multiconducteur

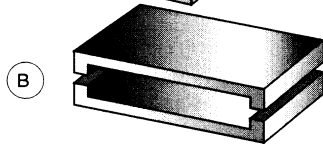

B Tore pour câble en nappe



C Ferrite CMS, taille 3,2 x 1,6 x 1,1 (mm)
(sources : MURATA, STEWARD)

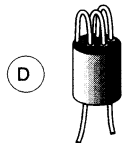

D Ferrite 6 trous, 3 tours
(source : PHILIPS VK 200)

Impédance donnée pour 1 passage ($N = 1$).
pour $N = 2$, ou 3, Z est multiplié par N^2 jusqu'à environ 100 MHz

Ferrite core = localised effect
Distributed effect?



Power / signal lines

Lossy cables

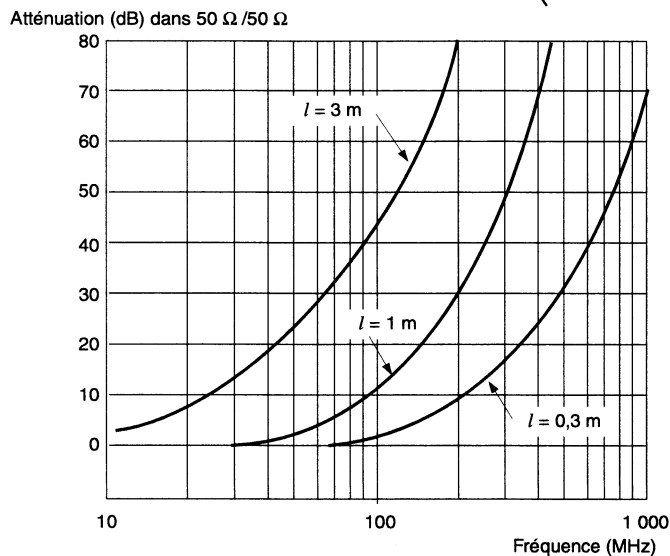
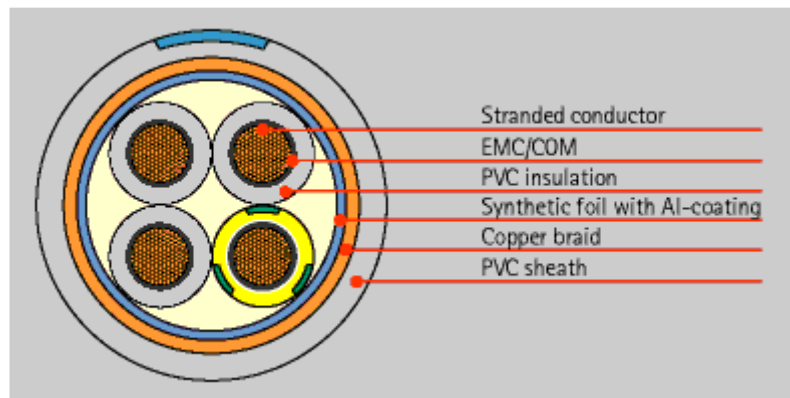
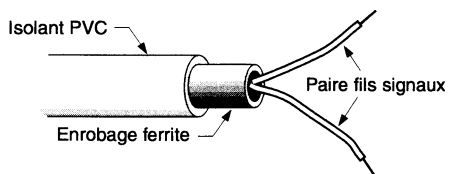

MOTOR DRIVE CABLE LiMY(St)CY-JZ 4 x 2,5 Typical attenuation versus frequency

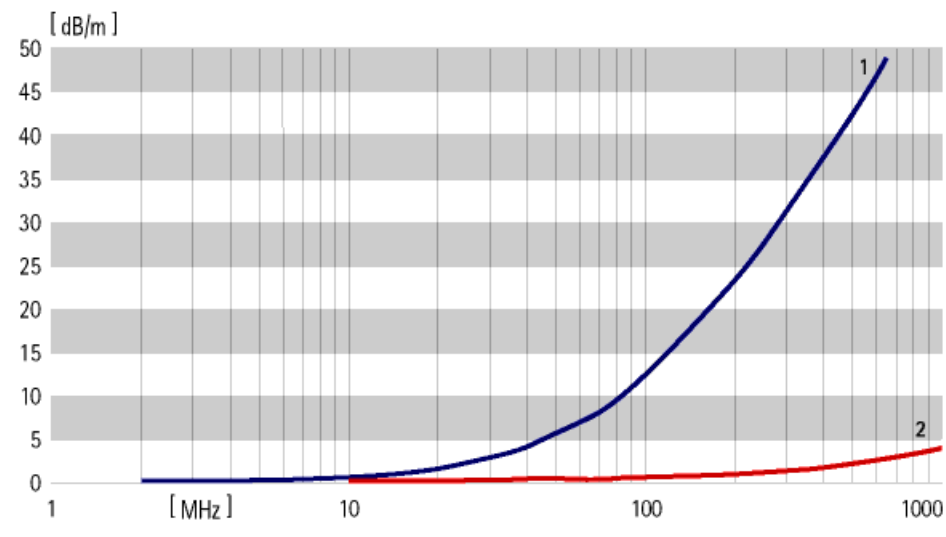

1 : LiMY(St)CY 2 : standard cable



Power / signal lines

Lossy cables

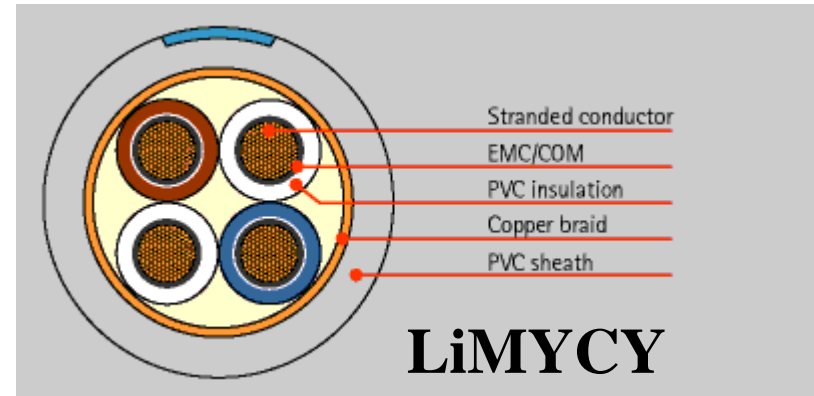
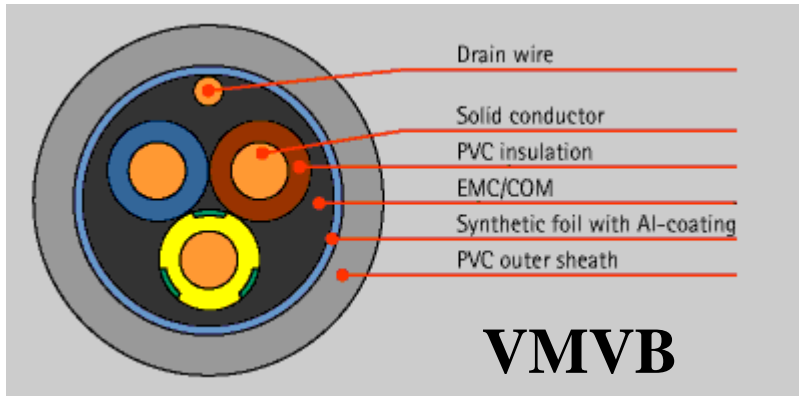

VMVB Installation Cable Common Mode Attenuation in dB/m

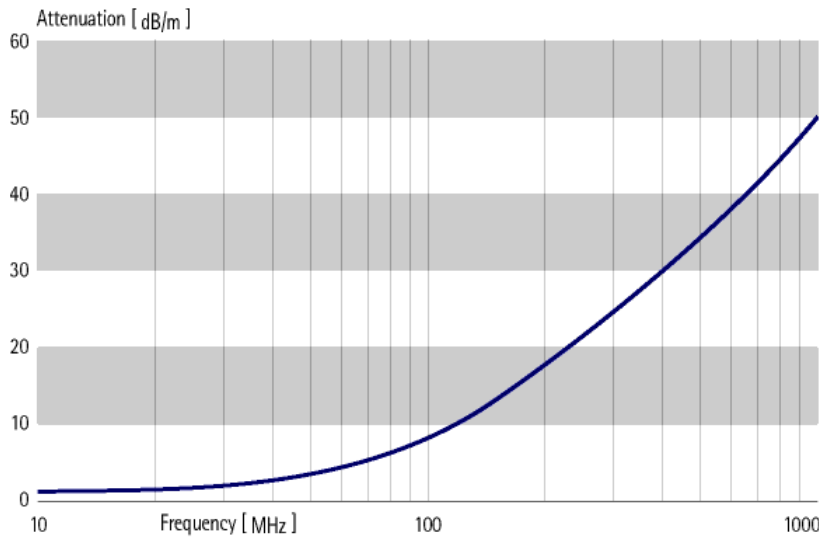

LP/CABLE LiMYCY Typical attenuation of both common and differential mode disturbances versus frequency - all types

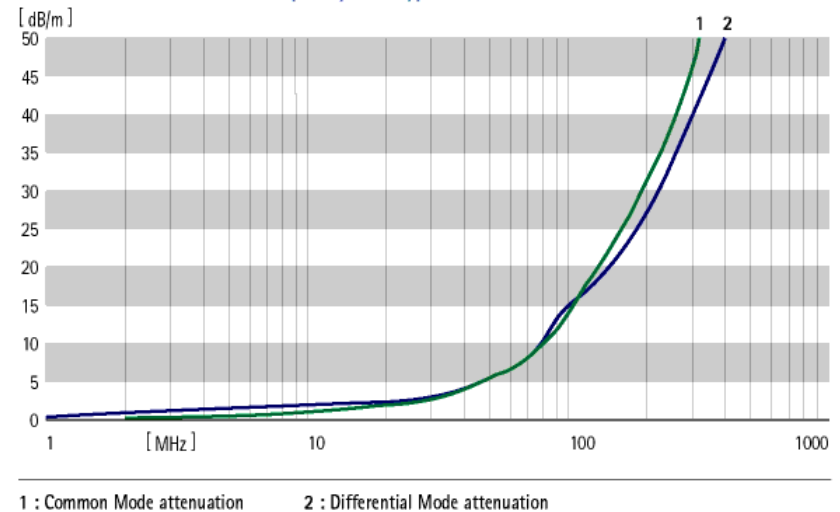



Twisted cables

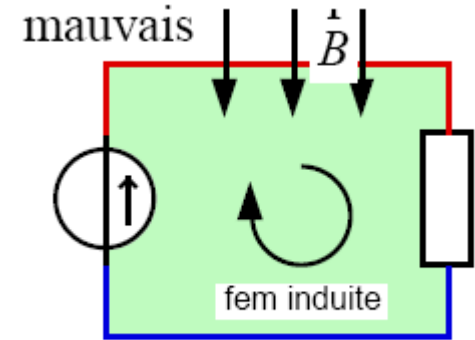
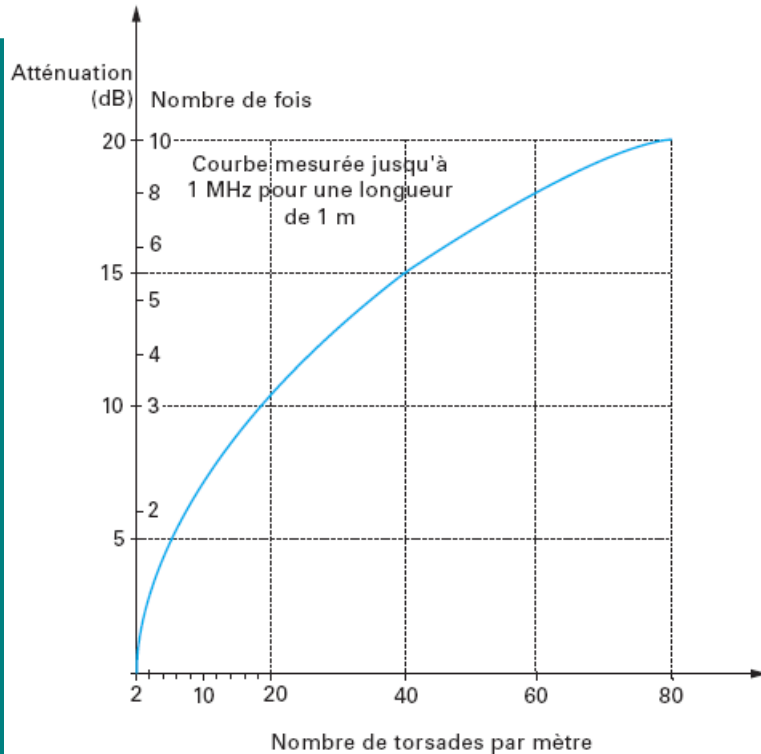

Nombre de torsades par mètre

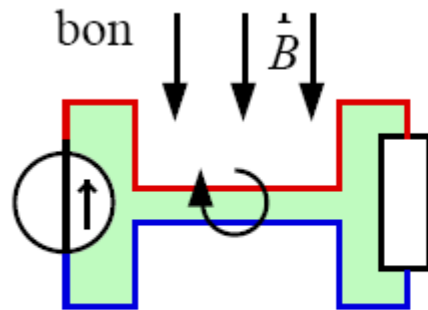

excellent :

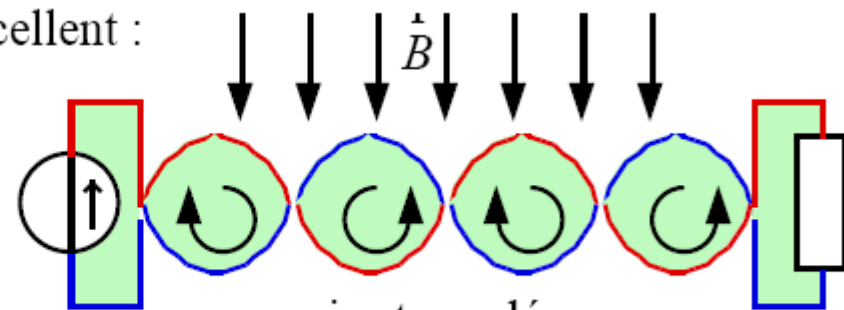

paire torsadée

(NB : les torsades sont grossies pour les besoins du schéma)



Shielded cables

A shielded cable is characterised by its transfer impedance Z_t .

Lets consider a coaxial cable over a conductive plane (figure). We connect at one end between shielding and ground plane a source E_0 with an internal impedance Z_0 . At the other end, the shielding is connected to the ground plane with a short-circuit. I_0 is the induced current in the shielding. The central conductor is open at one end and short-circuit at the other end. V_{int} is the image of the shielding defects (I_0 on the shielding).

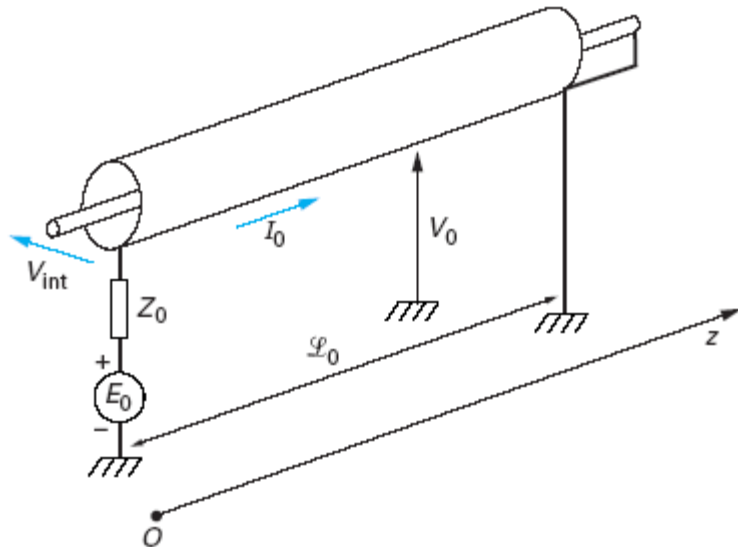

Z_t is V_{int} over I_0 , in Ω/m .

Z_t is a function of physical characteristics and geometry

- homogeneous tubular shielding
- braided shielding
- helicoidally shielded



Shielded cables

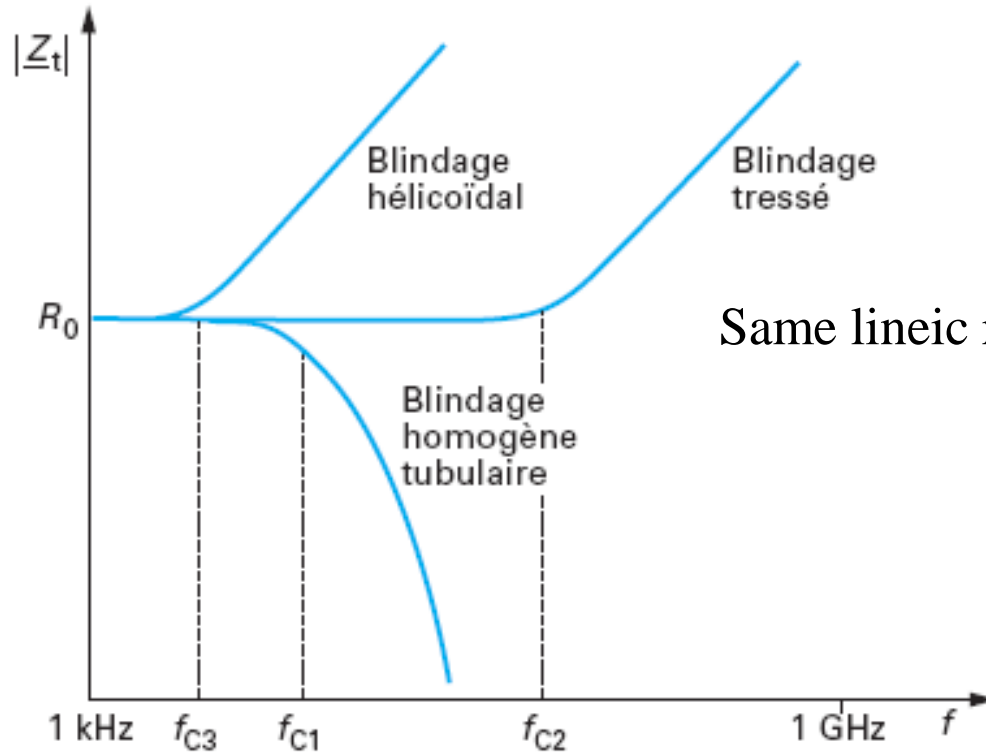

Same lineic resistance $6\text{m}\Omega/\text{m}$ (typ.)



Do not confuse metallic armature (mechanical) and shielding.



Shielded cables



Multi-pair cable
Double shielding
with aluminium sheet and
tinned braid



Multiconductor cable
aluminium shielding



Multi-pair cable
Shielding for each pair
and general shielding
(tinned copper braid)



Multiconductor cable
+ shielding
(tinned copper braid)



Shielded cables

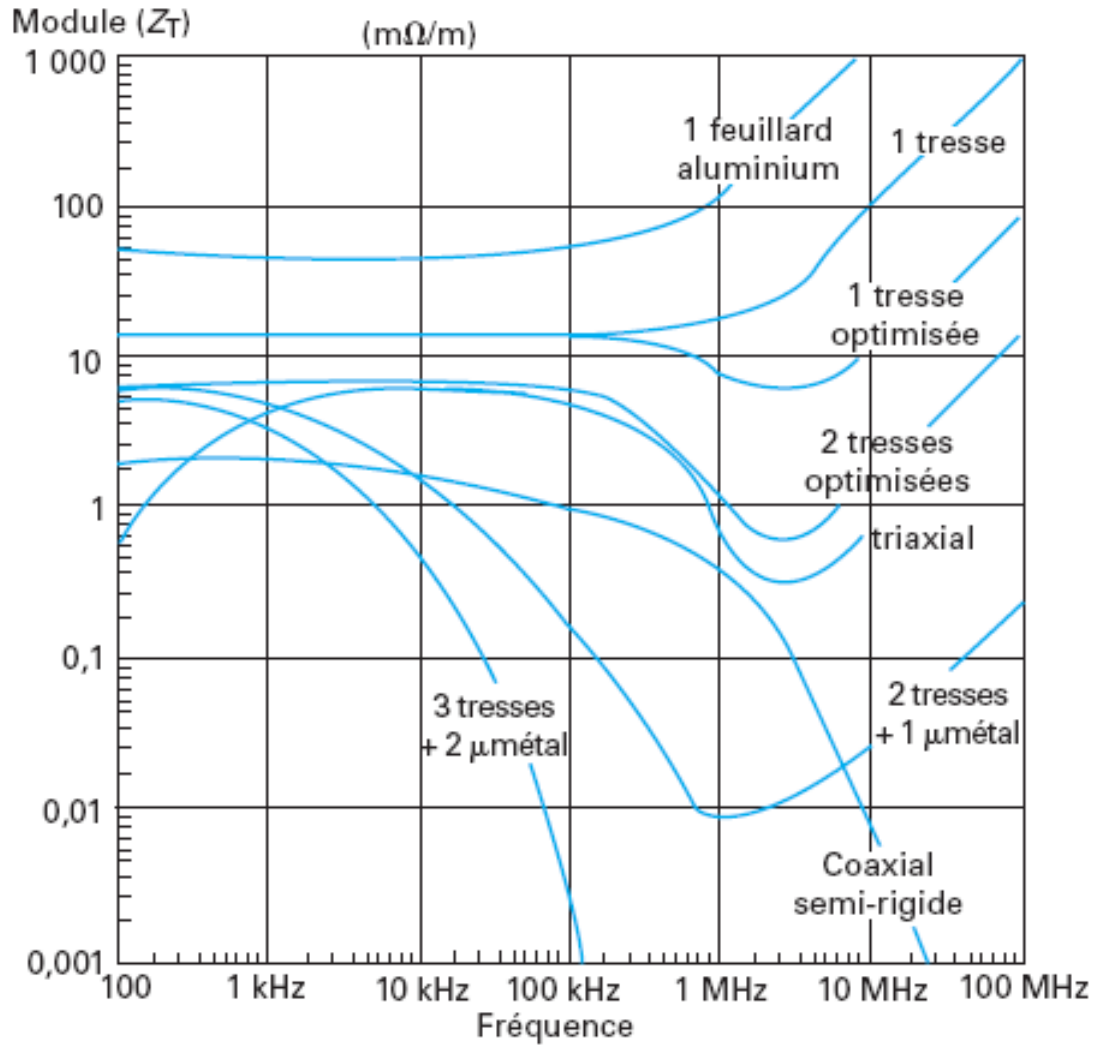



Shielded cables

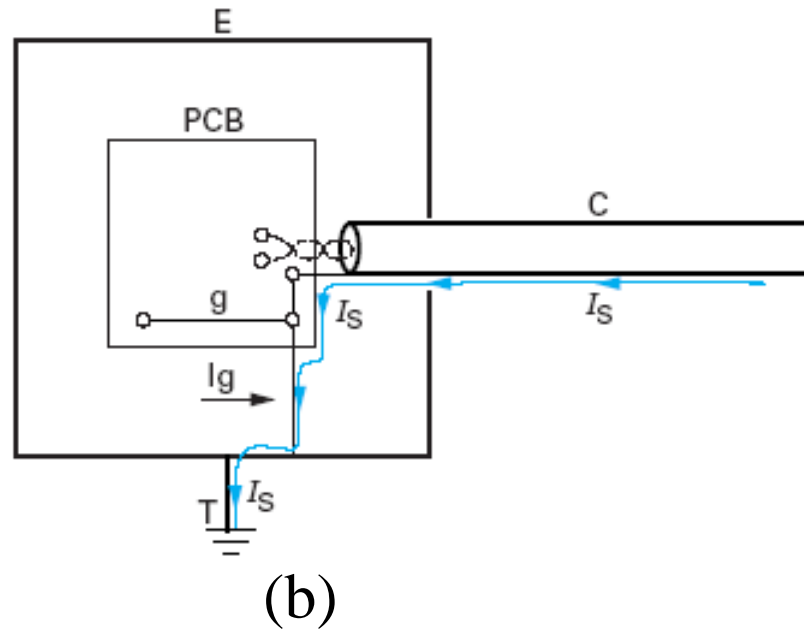
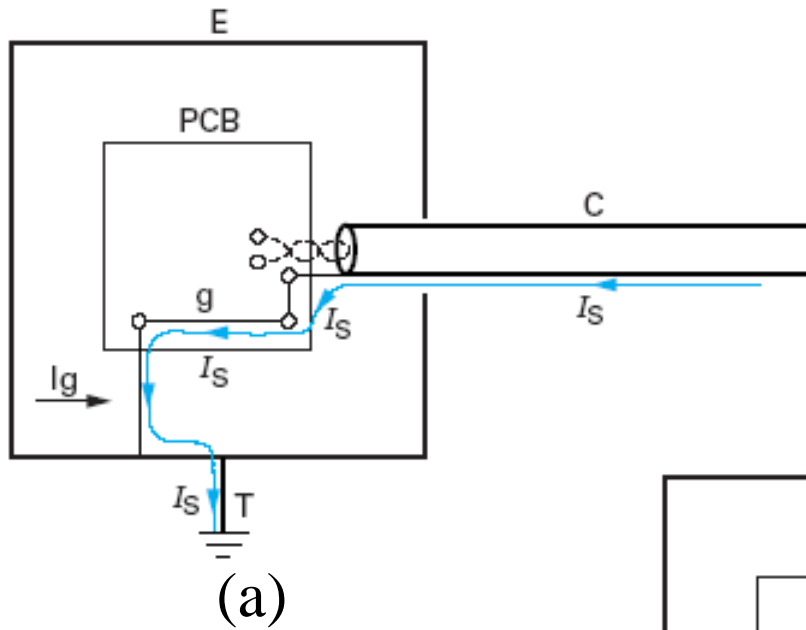



Shielded cables

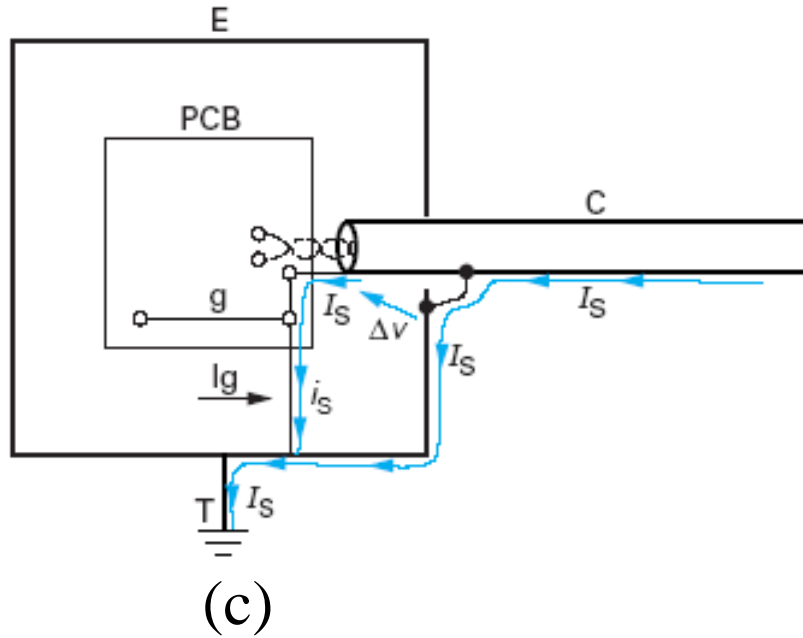



Shielded cables

End of shielding braid? Solutions [Radialex®]

