



Electromagnetic Energy Conversion

ELEC0431

Exercise session 10: Elements of Power Electronics

10 April 2026

Florent Purnode (florent.purnode@uliege.be)

Montefiore Institute, Department of Electrical Engineering and Computer Science,
University of Liège, Belgium

In this class...

- Inductor in steady state → Volt-second balance
- Capacitor in steady state → Amp-second balance
- PWM input voltage: The duty cycle
- The buck converter
- Current ripples Δi_L
- Exercises 15 & 16

Transient response of an inductor

NB: This slide is for introductory purposes only (not part of the exam).

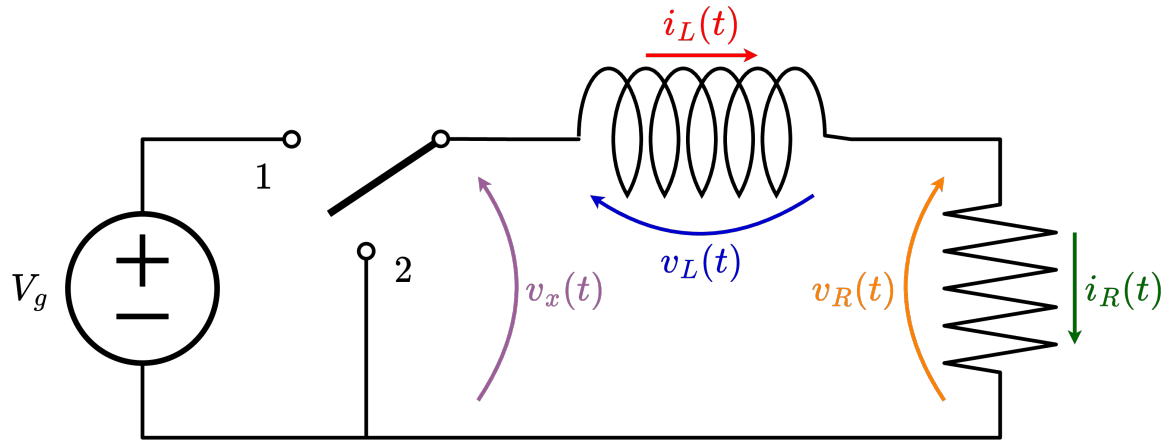

$$v_x(t) = v_L(t) + v_R(t)$$

$$v_L(t) = L \frac{di_L(t)}{dt} = L \frac{di(t)}{dt}$$

$$v_R(t) = R i_R(t) = R i(t)$$

$$v_x(t) = L \frac{di(t)}{dt} + R i(t)$$

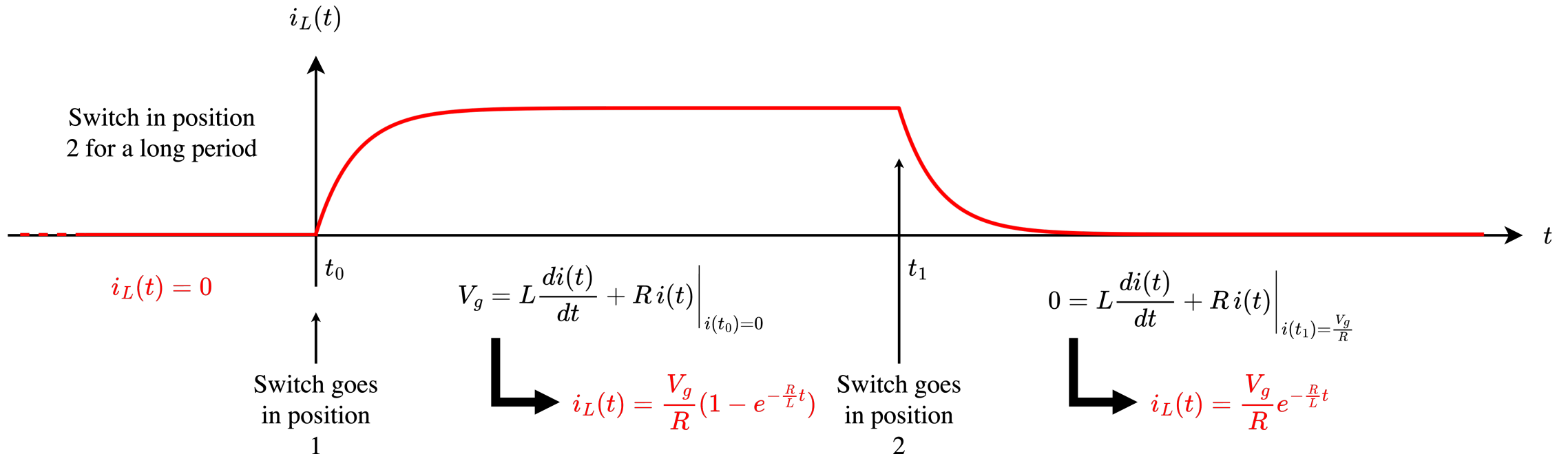

RL circuit with square input voltage → SRA

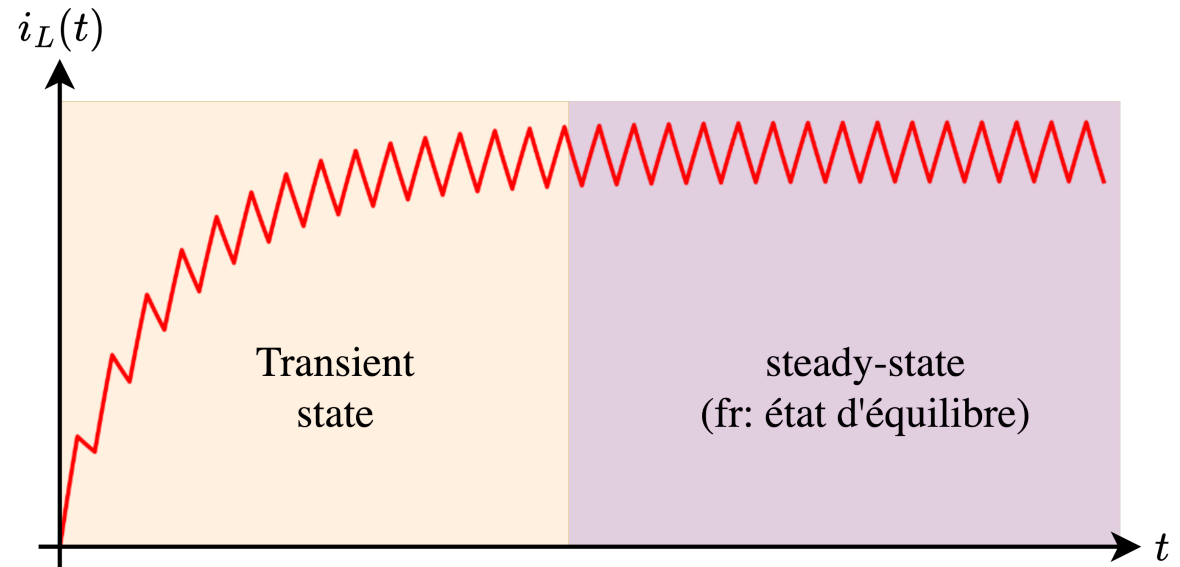
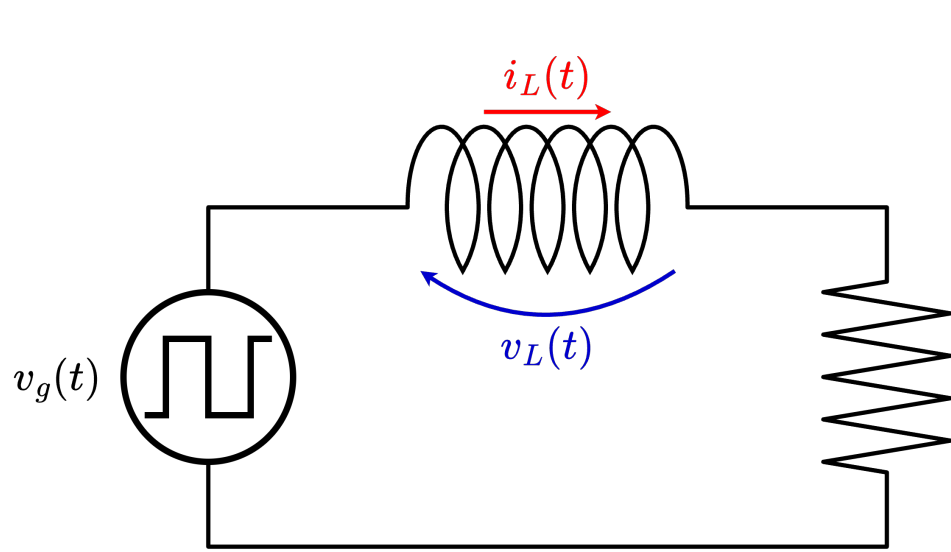

For well-chosen values of L , R , and frequency, the RL circuit reaches a steady state in which the current can be decomposed into a DC component I_L and a ripple component $i_L^{ripple}(t)$:

$$i_L(t) = I_L + i_L^{ripple}(t)$$

In DC-DC converters, the ripple is often much smaller than the DC part:

Small ripple approximation (SRA): $I_L \gg i_L^{ripple}(t) \Rightarrow i_L(t) \approx I_L$

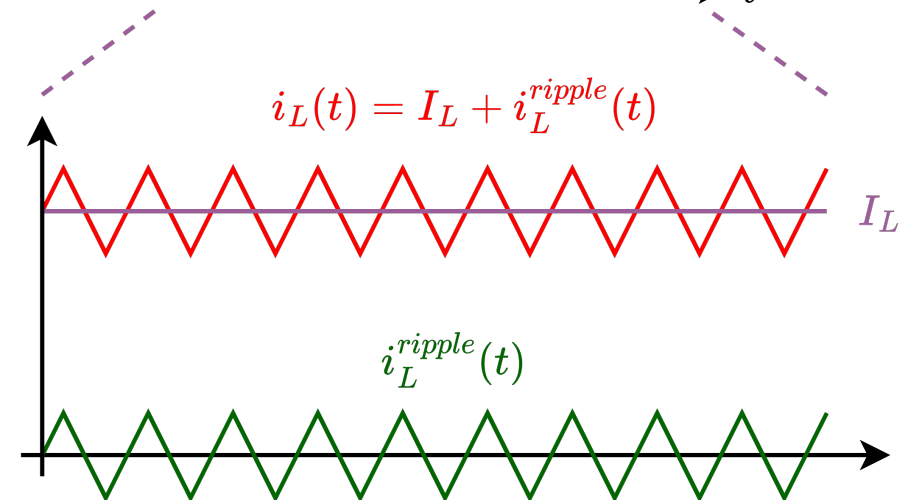

Inductor in steady state → Volt-second balance

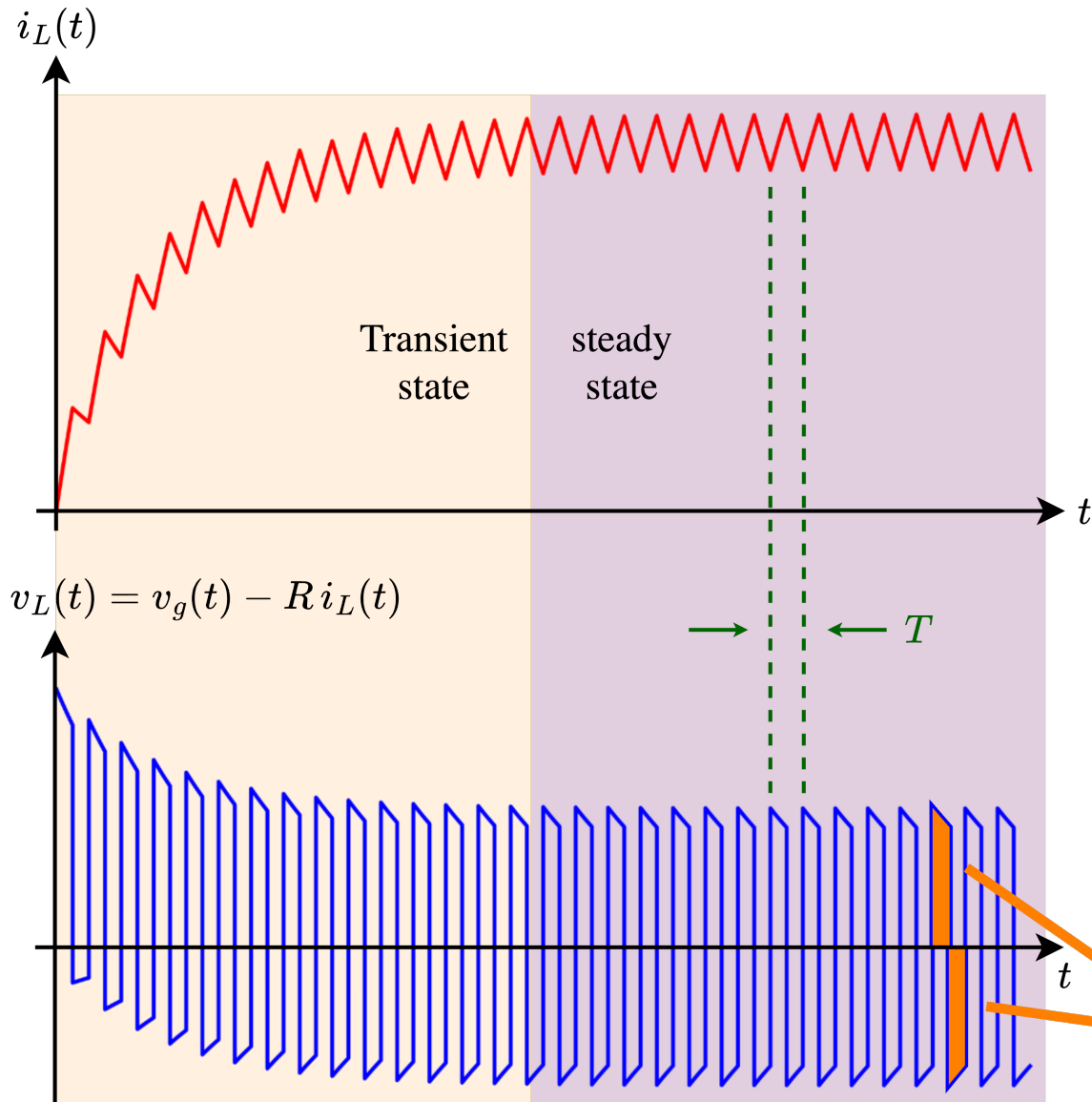

In steady state, the inductor current repeats every period T :

$$i_L(t_0 + T) - i_L(t_0) = 0$$

$$\Downarrow v_L(t) = L \frac{di_L(t)}{dt}$$

$$\int_0^{t_0+T} \frac{v_L(t)}{L} dt - \int_0^{t_0} \frac{v_L(t)}{L} dt = \int_{t_0}^{t_0+T} \frac{v_L(t)}{L} dt = 0$$

Volt-second balance

In steady-state operation, the average voltage across an inductor is zero over one switching period:

$$\langle v_L(t) \rangle = \frac{1}{T_s} \int_{t_0}^{t_0+T} v_L(t) dt = 0$$

Identical areas

Transient response of a capacitor

NB: This slide is for introductory purposes only (not part of the exam).

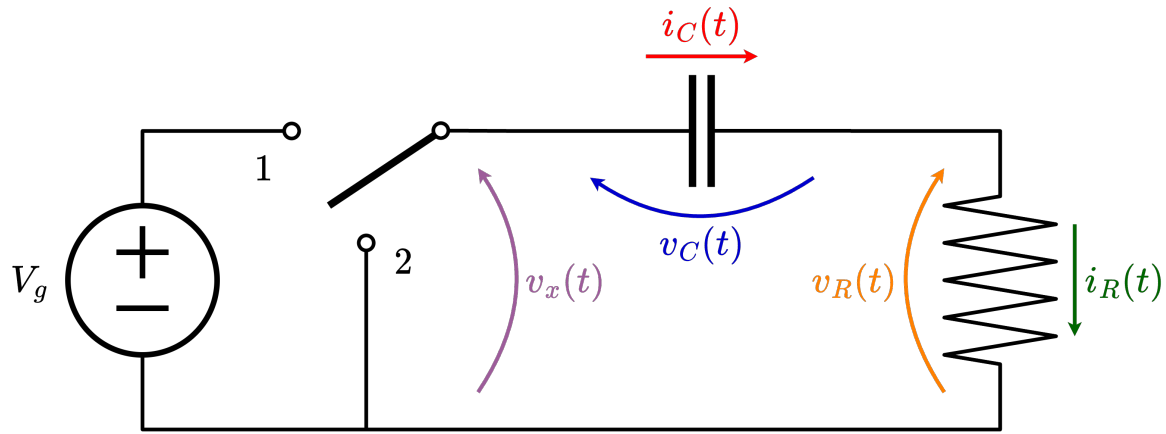

$$\left. \begin{aligned} v_x(t) &= v_C(t) + v_R(t) \\ i_C(t) &= i(t) = C \frac{dv_C(t)}{dt} \\ i_R(t) &= i(t) = \frac{v_R(t)}{R} \end{aligned} \right\} C \frac{dv_C(t)}{dt} = \frac{v_x(t) - v_C(t)}{R}$$

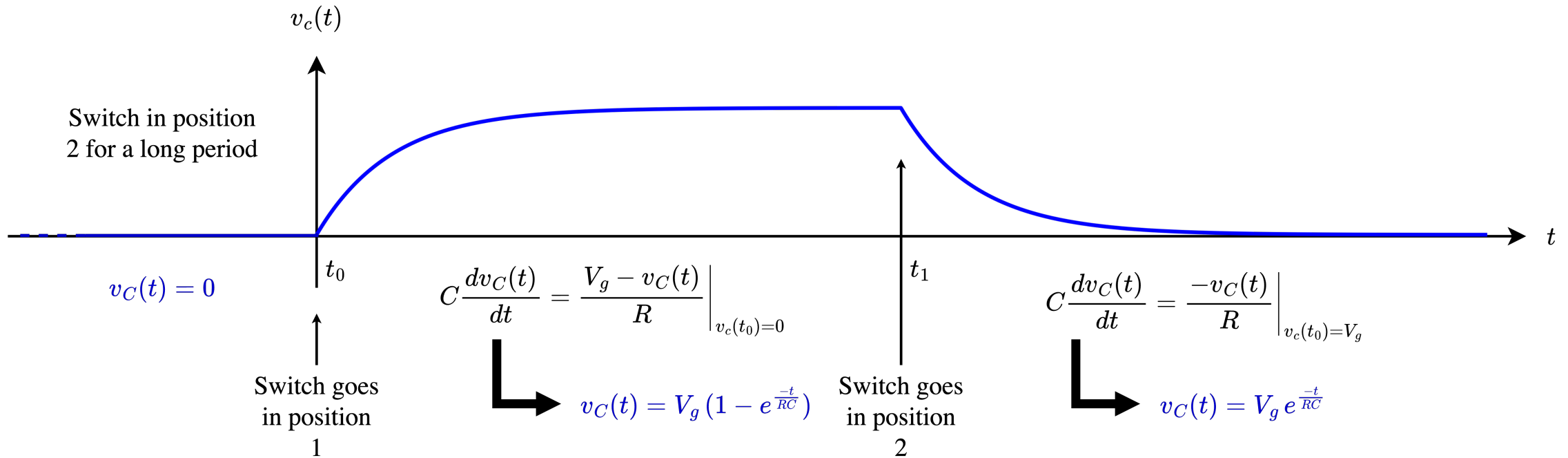

RC circuit with square input voltage → SRA

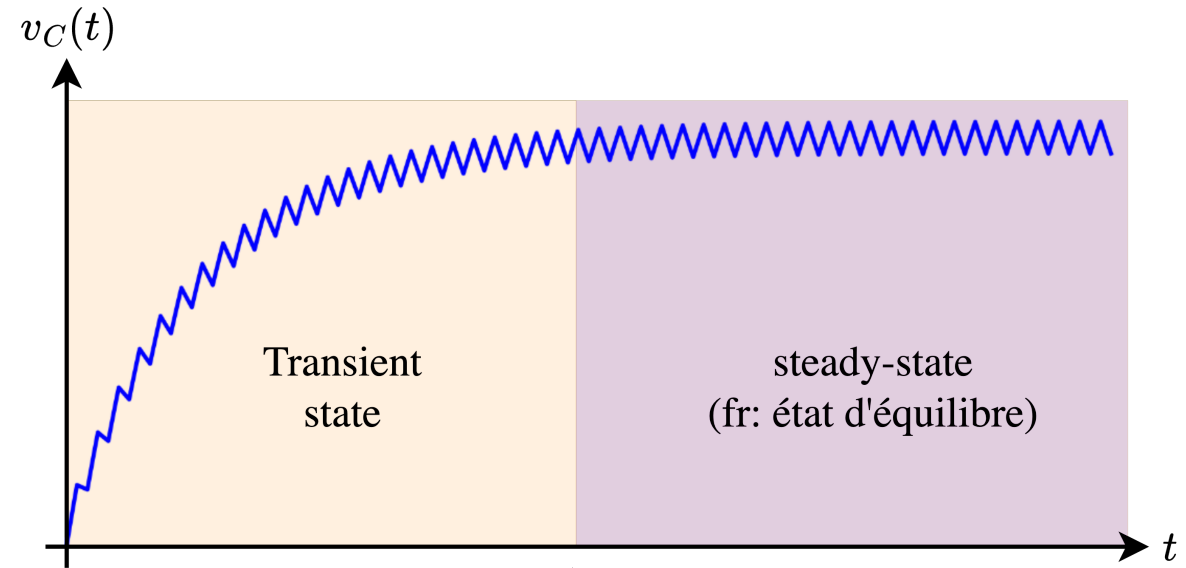
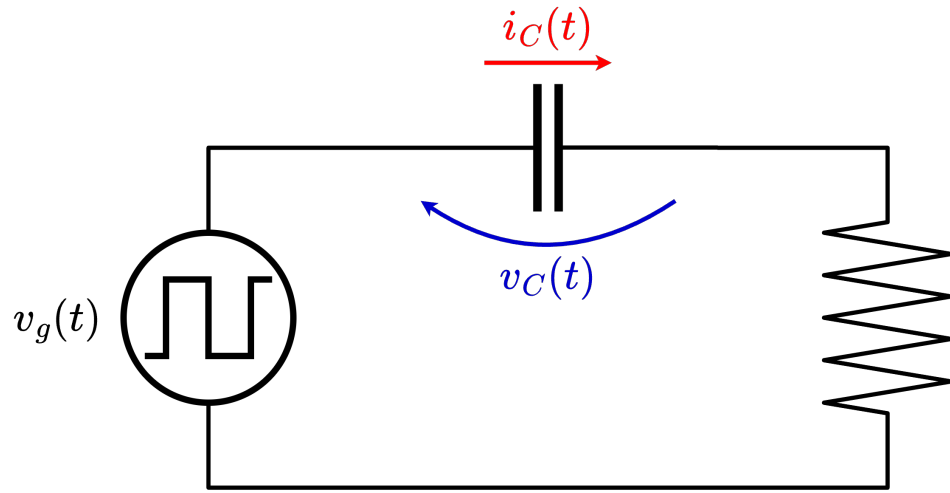

For well-chosen values of C , R , and frequency, the RC circuit reaches a steady state in which the voltage can be decomposed into a DC component V_C and a ripple component $v_C^{ripple}(t)$:

$$v_C(t) = V_C + v_C^{ripple}(t)$$

In DC-DC converters, the ripple is often much smaller than the DC part:

Small ripple approximation (SRA): $V_C \gg v_C^{ripple}(t) \Rightarrow v_C(t) \approx V_C$

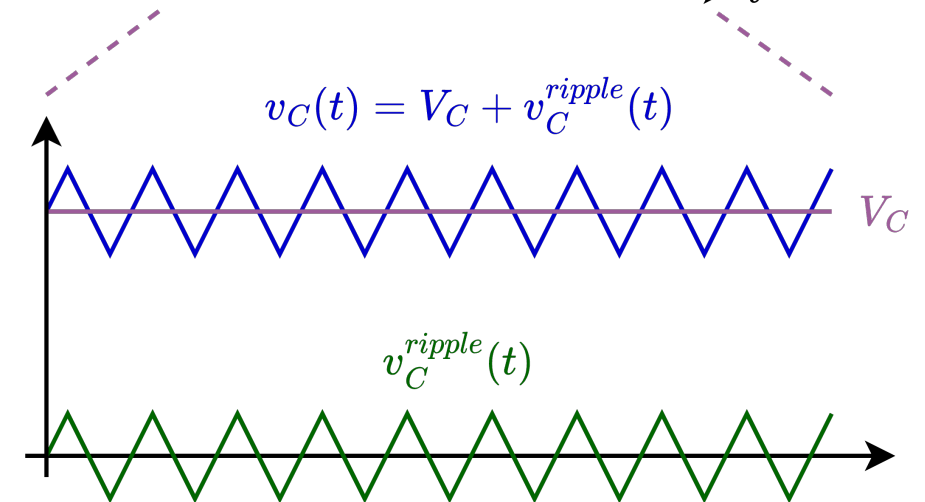

Capacitor in steady state → Amp-second balance

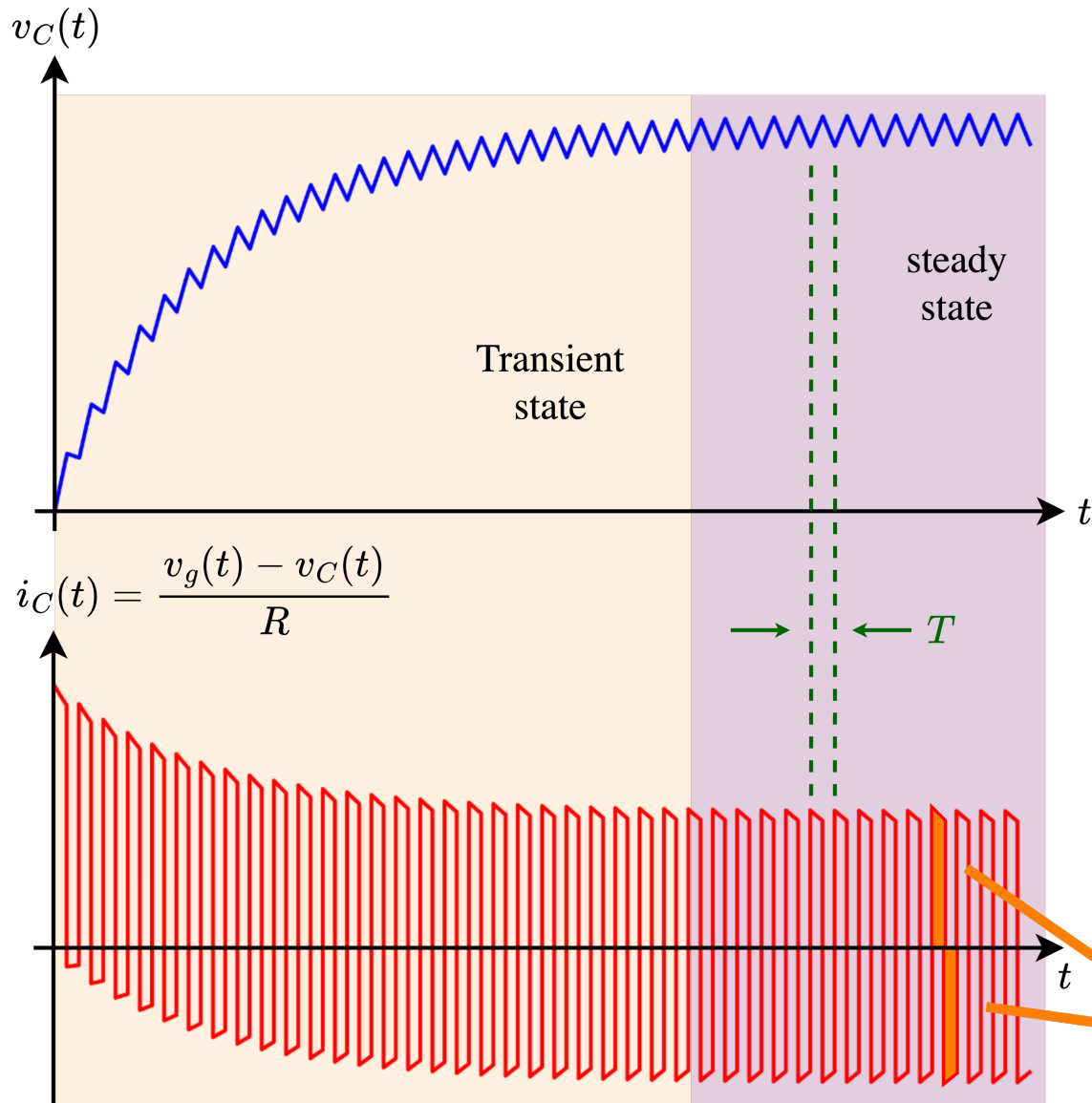

In steady state, the capacitor voltage repeats every period T :

$$v_L(t_0 + T) - v_L(t_0) = 0$$

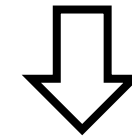

$$i_C(t) = C \frac{dv_L(t)}{dt}$$

$$\int_0^{t_0+T} \frac{i_C(t)}{C} dt - \int_0^{t_0} \frac{i_C(t)}{C} dt = \int_{t_0}^{t_0+T} \frac{i_C(t)}{C} dt = 0$$

Amp-second balance

In steady-state operation, the average current through a capacitor is zero over one switching period:

$$\langle i_C(t) \rangle = \frac{1}{T_s} \int_{t_0}^{t_0+T} i_C(t) dt = 0$$

Inductors & capacitors in steady state: recap

Inductor

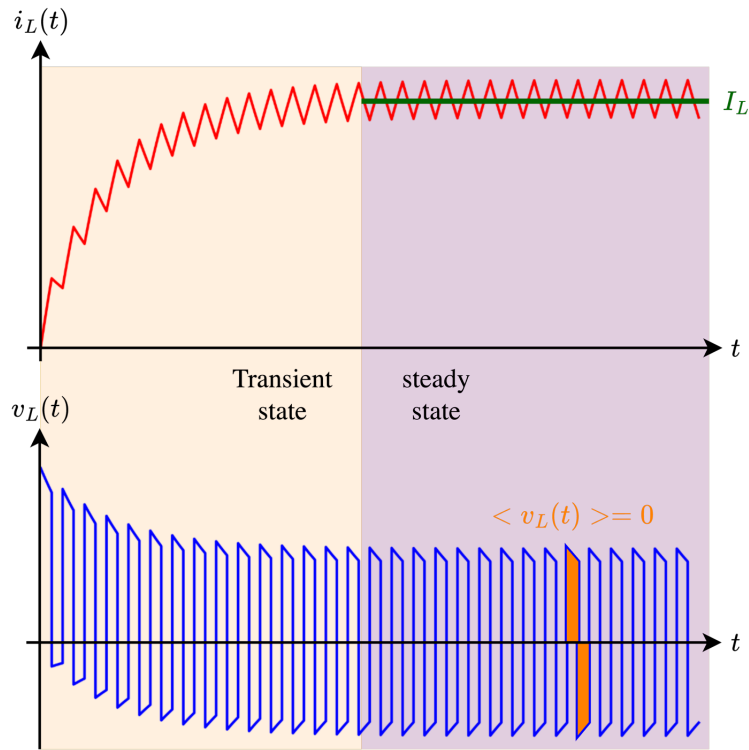

Small ripple approximation (SRA) for **inductor current**

$$i_L(t) \approx I_L$$

Volt-second balance for **inductor voltage**

$$\langle v_L(t) \rangle = \frac{1}{T} \int_{t_0}^{t_0+T} v_L(t) dt = 0$$

Capacitor

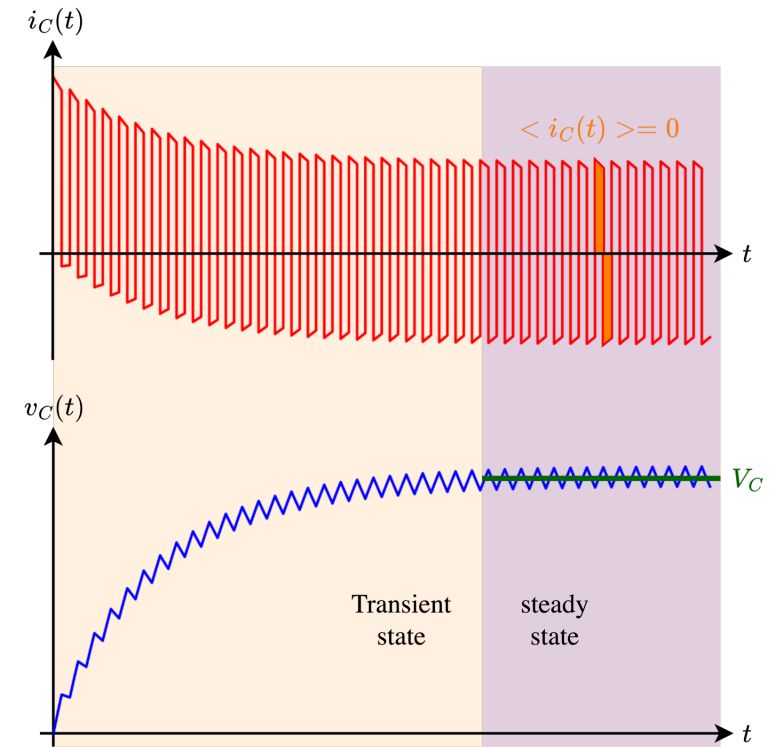

Small ripple approximation (SRA) for **capacitor voltage**

$$v_C(t) \approx V_C$$

Amp-second balance for **capacitor current**

$$\langle i_C(t) \rangle = \frac{1}{T} \int_{t_0}^{t_0+T} i_C(t) dt = 0$$

PWM input voltage: The duty cycle

PWM: Pulse width modulation

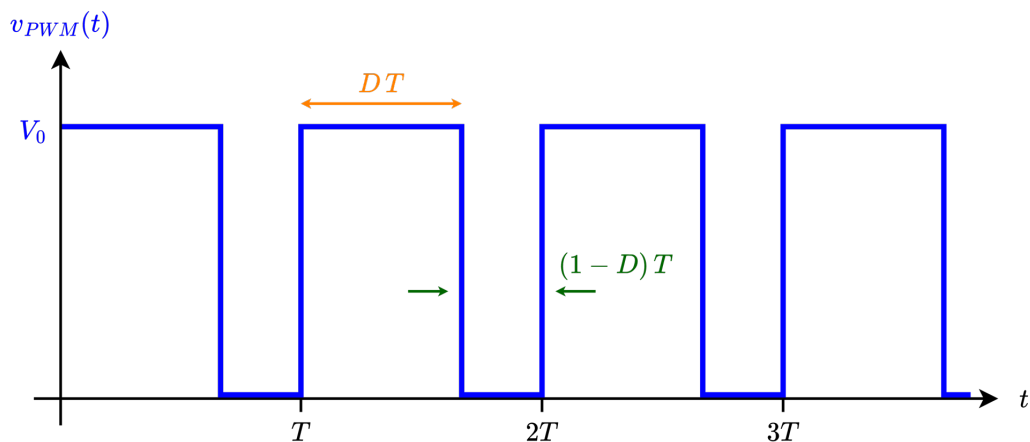

$$v_{PWM}(t) = \begin{cases} V_0 & \forall t \in [nT; nT + DT] \\ 0 & \forall t \in [nT + DT; (n+1)T] \end{cases}, n \in \mathbb{N}$$

D is the duty cycle, that is the percentage of time the voltage is high
 $\Rightarrow D \in [0; 1]$

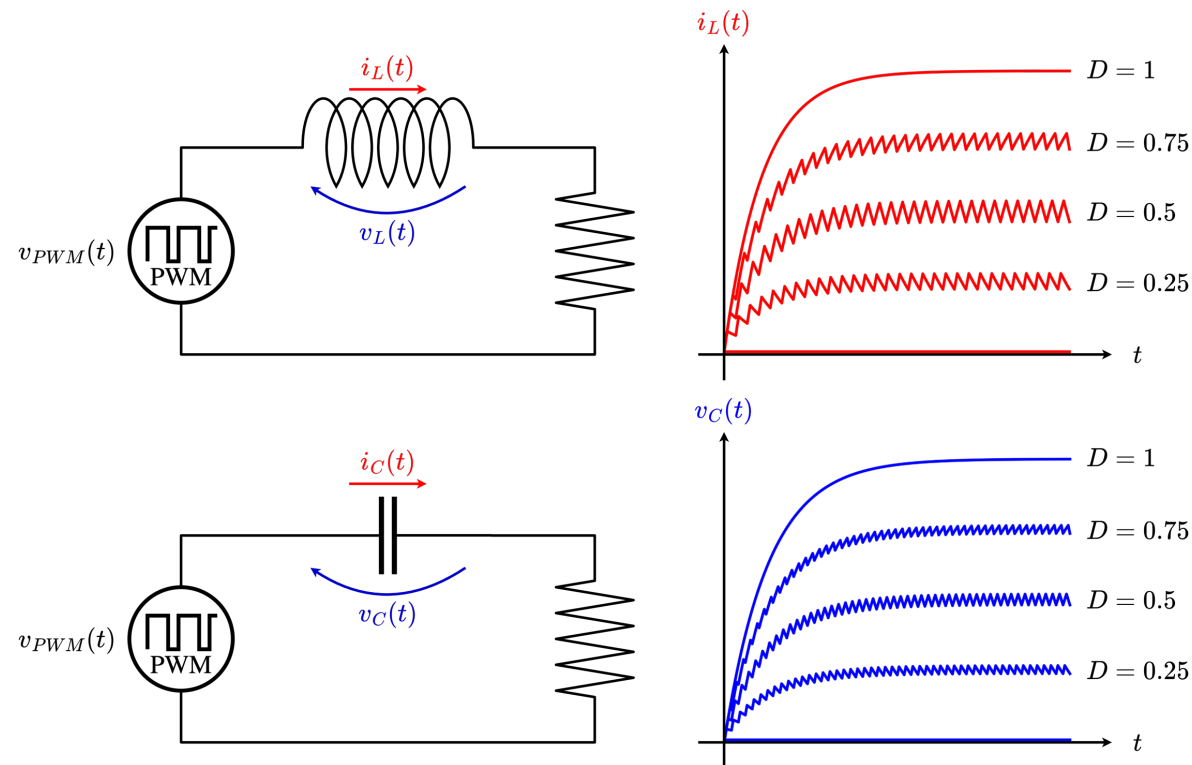

By modifying the duty cycle D , one can control the mean voltage / current.

Note: In steady state, only one period is enough to describe the circuit behavior.

A basic DC-DC converter: the buck converter

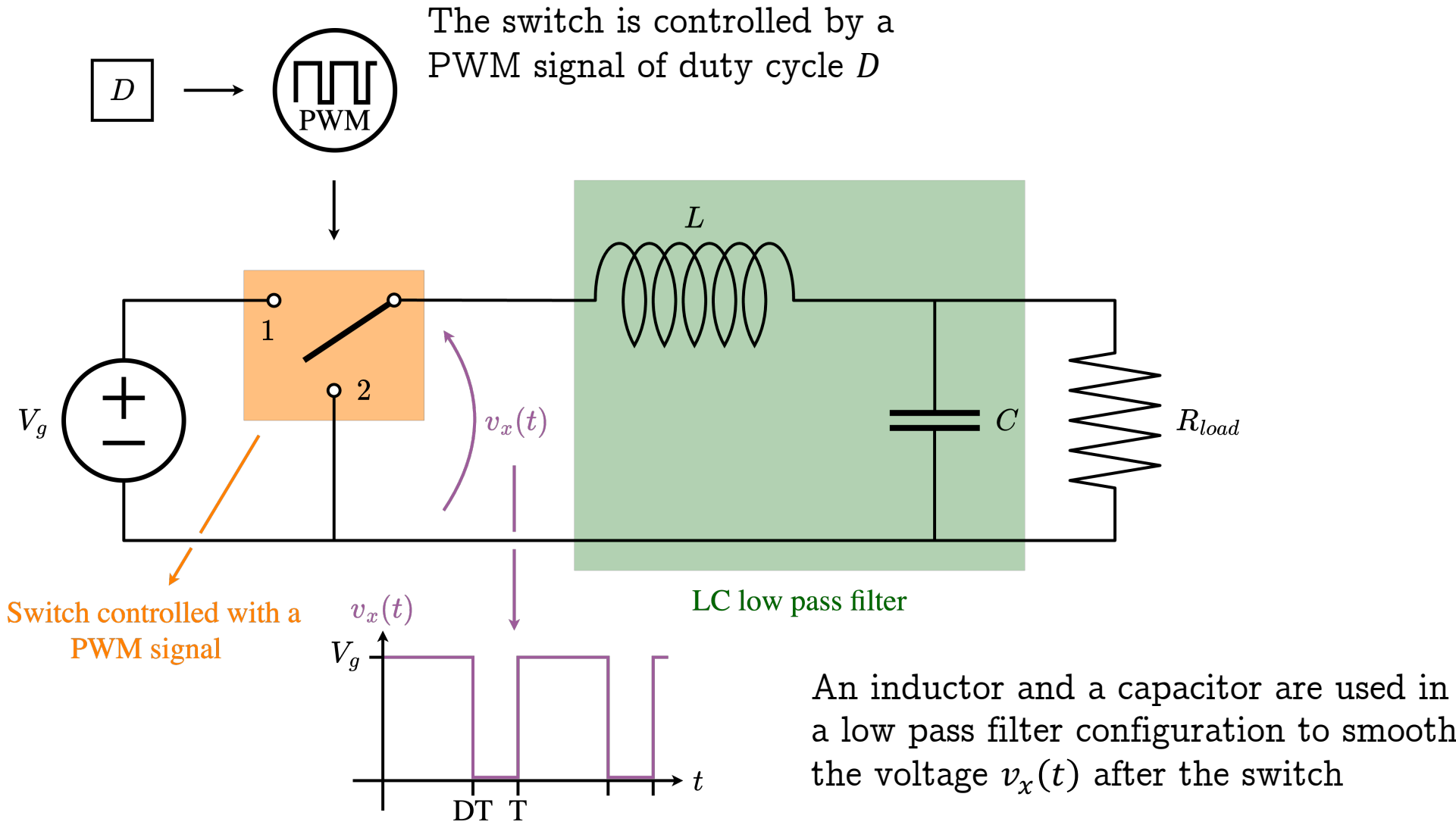

DC-DC converter analysis - Methodology

To analyze a DC-DC converter:

1. Apply the small ripple approximation (SRA) to the currents through the inductors and to the voltages across the capacitors
2. Subdivide the circuit according to the duty cycle
3. For each sub-circuit, express the voltages across the inductors and the currents through the capacitors
4. Apply the volt-second balance on the inductor voltages and solve the system
5. Apply the amp-second balance on the capacitor currents and solve the system
6. From the voltage across the inductor, determine the inductor current ripples

→ Example with a buck converter

1. Apply the small ripple approximation (SRA)

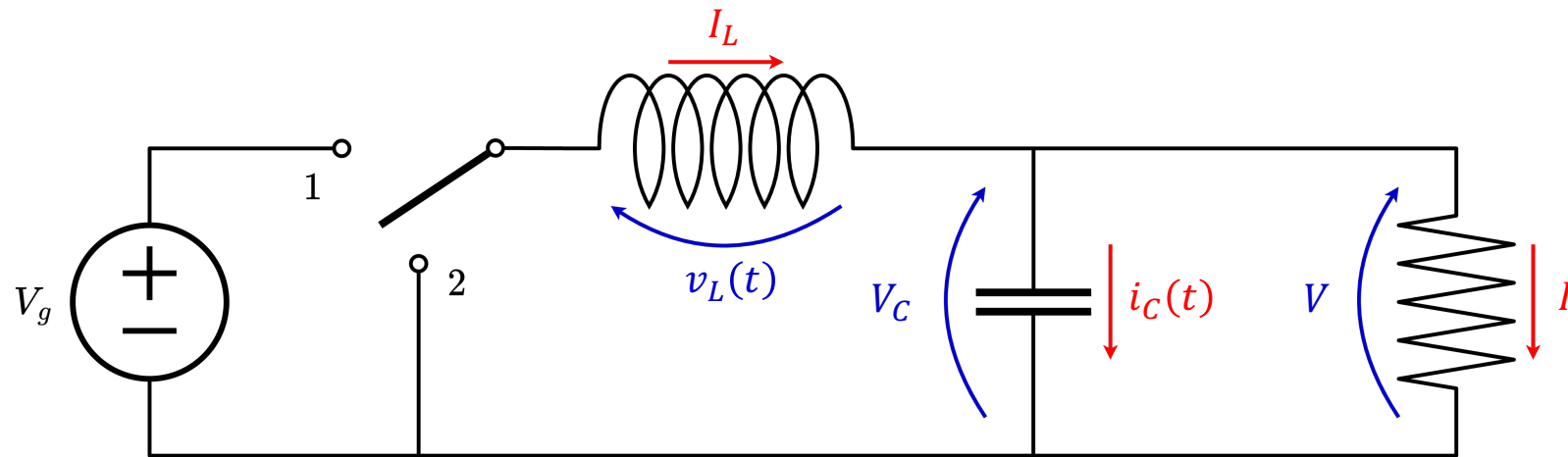
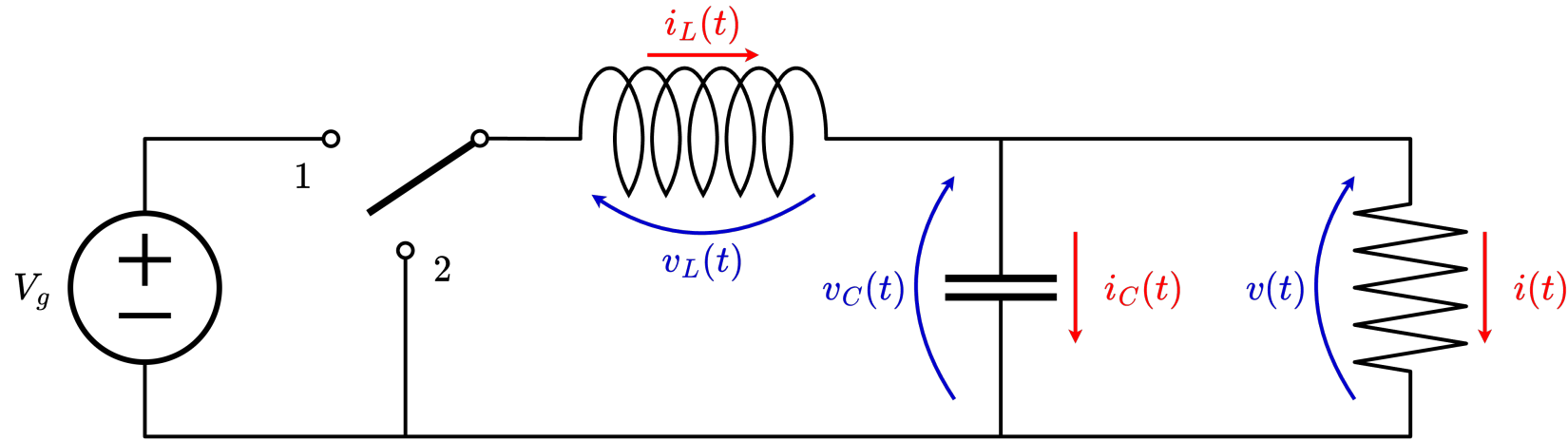

SRA

2. Subdivide the circuit

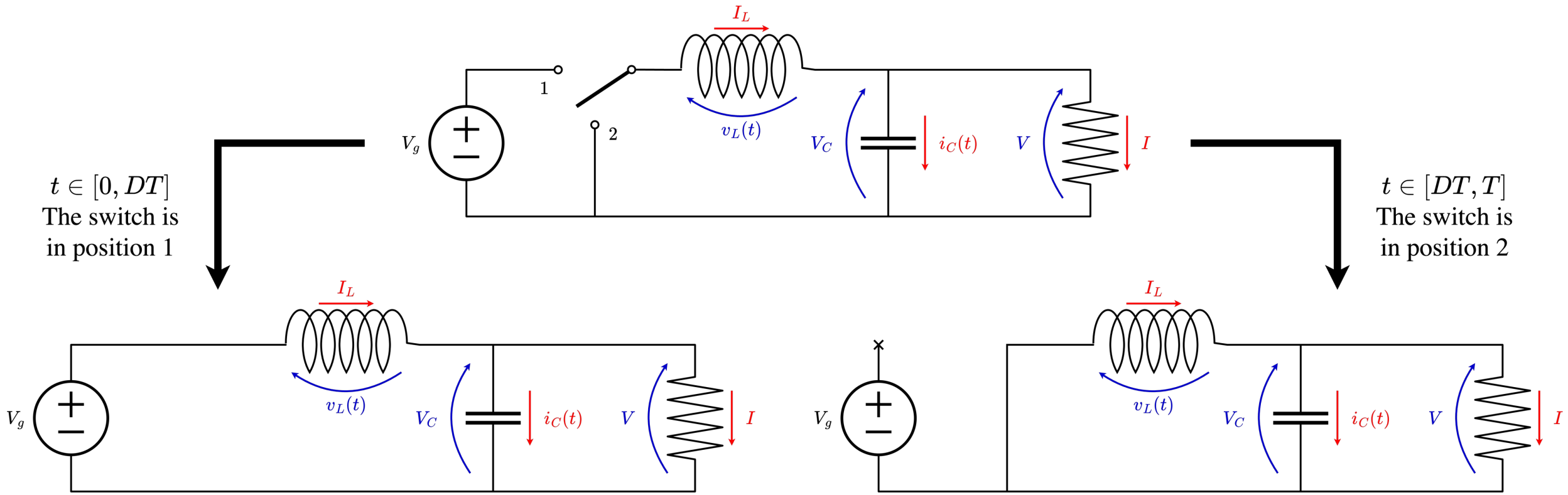

Make sure to use the same conventions in both subcircuits.
The current direction **MUST** remain the same.
The voltage direction **MUST** remain the same.

3. Express v_L and i_C

Express v_L and i_C in terms of quantities on which the SRA has been applied.

$t \in [0, DT]:$

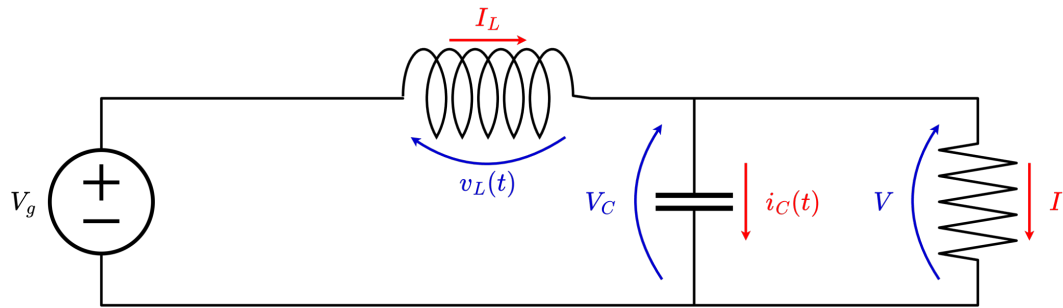

$$v_L = V_g - V$$
$$i_C = I_L - \frac{V}{R}$$

$t \in [DT, T]:$

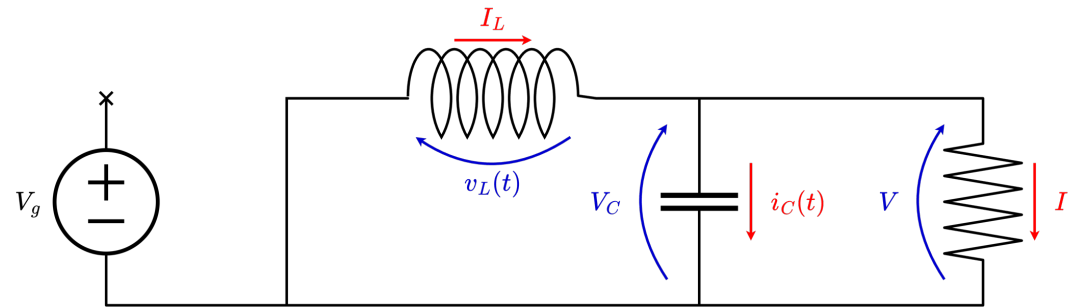

$$v_L = -V$$
$$i_C = I_L - \frac{V}{R}$$

4. Volt-second balance – 5. Amp-second balance

$$t \in [0; DT]$$

$$v_L = V_g - V$$

$$i_C = I_L - \frac{V}{R}$$

$$t \in [DT; T]$$

$$v_L = -V$$

$$i_C = I_L - \frac{V}{R}$$

Volt-second balance:

$$\begin{aligned} \langle v_L(t) \rangle &= \frac{1}{T} \int_0^T v_L dt \\ &= \frac{1}{T} \int_0^{DT} v_L dt + \frac{1}{T} \int_{DT}^T v_L dt \\ &= \frac{1}{T} \int_0^{DT} (V_g - V) dt + \frac{1}{T} \int_{DT}^T -V dt \\ &= D(V_g - V) + (1 - D)(-V) \\ &= 0 \end{aligned}$$

$$\Rightarrow D V_g - D V = V - D V$$

$$\Rightarrow M(D) = \frac{V}{V_g} = D$$

Amp-second balance:

$$\begin{aligned} \langle i_C(t) \rangle &= \frac{1}{T} \int_0^T i_C dt \\ &= \frac{1}{T} \int_0^{DT} i_C dt + \frac{1}{T} \int_{DT}^T i_C dt \\ &= \frac{1}{T} \int_0^{DT} \left(I_L - \frac{V}{R}\right) dt + \frac{1}{T} \int_{DT}^T \left(I_L - \frac{V}{R}\right) dt \\ &= D \left(I_L - \frac{V}{R}\right) + (1 - D) \left(I_L - \frac{V}{R}\right) \\ &= 0 \end{aligned}$$

$$\Rightarrow I_L = \frac{V}{R}$$

6. Current ripples Δi_L

$$\text{For } t \in [0, DT], \quad v_L(t) = V_g - V$$

$$\text{For } t \in [DT; T], \quad v_L(t) = -V$$

$$\Downarrow \quad v_L(t) = L \frac{di_L(t)}{dt}$$

$$\text{For } t \in [0, DT], \quad \frac{di_L(t)}{dt} = \frac{V_g - V}{L}$$

$$\text{For } t \in [DT; T], \quad \frac{di_L(t)}{dt} = -\frac{V}{L}$$

$$\Rightarrow 2 \Delta i_L = \frac{V_g - V}{L} DT = (1 - D) \frac{V_g}{L} DT$$

$$\Rightarrow \Delta i_L = \frac{1}{2} D (1 - D) \frac{V_g}{L} T$$

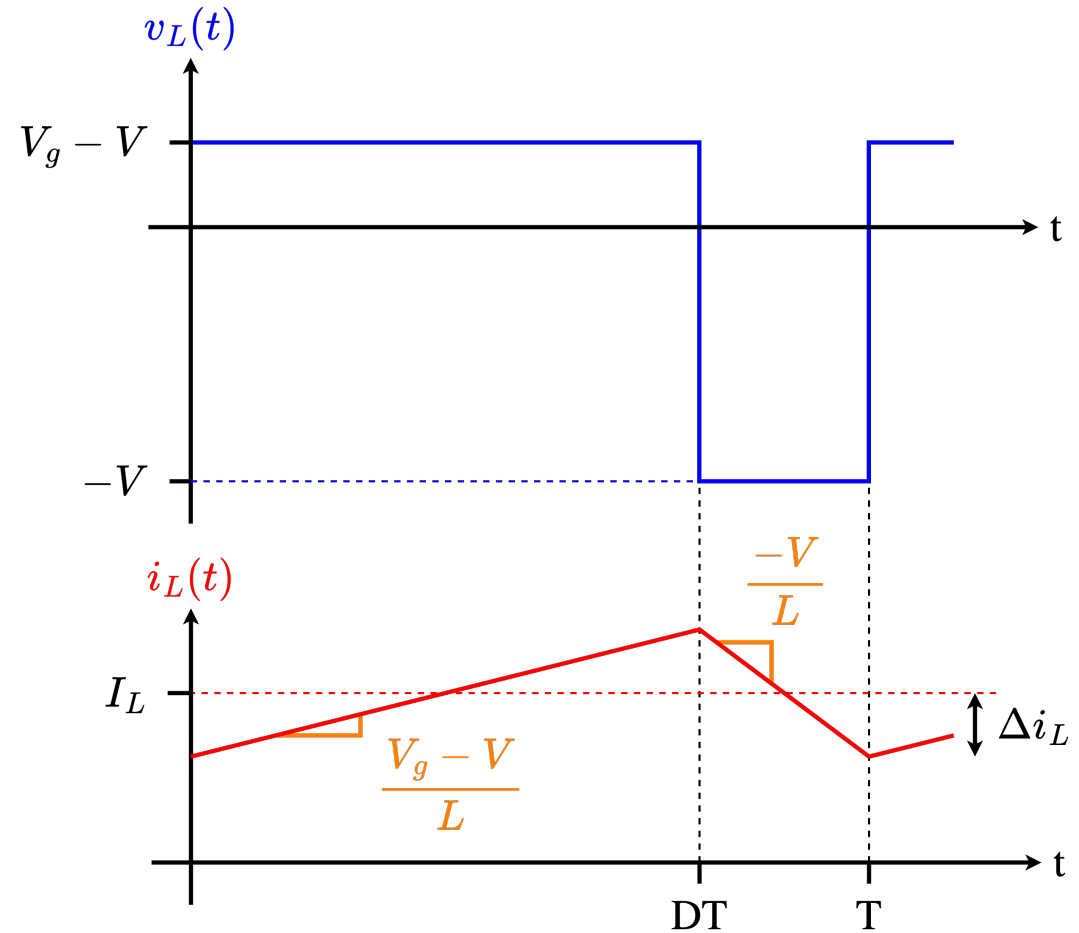

Exercises

Exercise 15: DC-DC boost converter

Exercise 16: H-bridge circuit

Exercise 15: DC-DC boost converter

In some electronic calculators, the battery provides a voltage $V_{in} = 3\text{ V}$, whereas the electronic parts work under 9 V . A DC-DC boost converter is used to increase the battery low voltage to the higher value (9 V) with high efficiency. The DC-DC boost converter can be modelled by the following circuit:

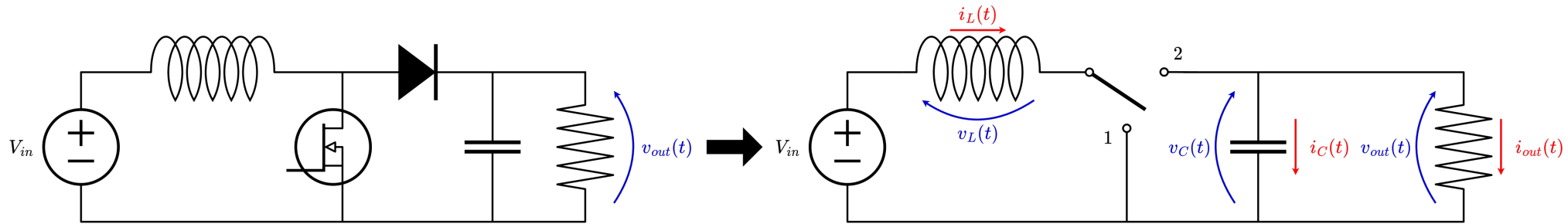

Assuming steady-state conditions:

1. Express the ratio $\frac{V_{out}}{V_{in}}$ in terms of the duty cycle D and find its value.
2. Express the mean current flowing through the inductor.
3. Draw the waveform of the voltage across the inductance. Deduce the inductance current waveform from it.
4. Estimate the inductor current ripple Δi_L for a switching frequency $f_s = 20\text{ KHz}$ and an inductance of 50 mH .

Exercise 16: H-bridge circuit

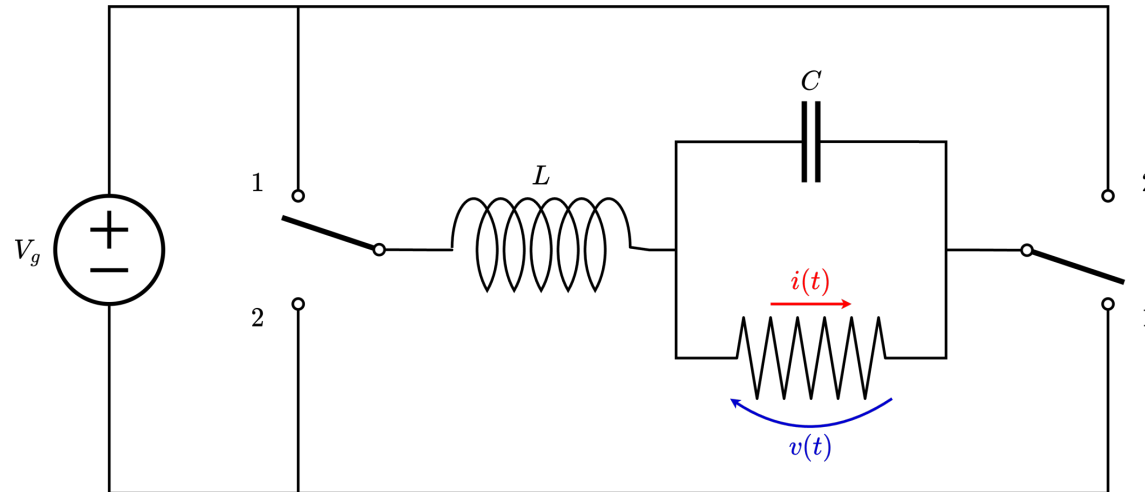

The above figure presents a H-bridge circuit. The switches operate synchronously:

- each in position 1 for $0 < t < DT$
- and in position 2 for $DT < t < T$.

Derive an expression for the voltage ratio $M(D) = \frac{V}{V_g}$ and for the mean current in the inductor.

Homework 22: DC-DC buck converter

In some models of an electric car, the battery voltage is set to $E = 302\text{ V}$, whereas the auxiliaries are working with $V_o = 12\text{ V}$. A DC-DC buck converter is used to reduce the battery high voltage to the lower value (12 V) with high efficiency. The DC-DC buck converter can be modelled by the following circuit.

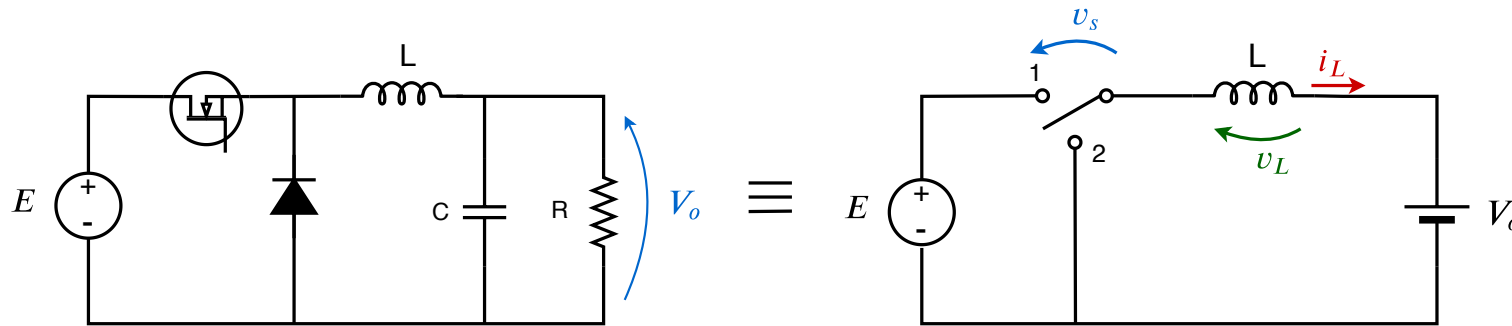

Assuming steady-state conditions:

1. Express the ratio $\frac{V_o}{E}$ in terms of the duty cycle D .
2. Give the value of D in this situation.
3. Find the expression of the inductor current ripple Δi_L in terms of V_o , E , D , T_s and L .
4. Estimate the inductor current ripple Δi_L for a switching frequency $f_s = 1\text{ KHz}$ and an inductance of 50 mH . Compare the value of the current ripple to the value of the output current if the auxiliaries draw 12 W .

Answers:

1. $V_o/E = D$

2. $D = 3.973\%$

3. $\Delta i_L = (E - V_o)DT_s / (2L)$

4. $\Delta i_L = 0.1152 I_L$

Homework 23: Buck-boost analysis

The figure on the right presents a buck-boost converter:

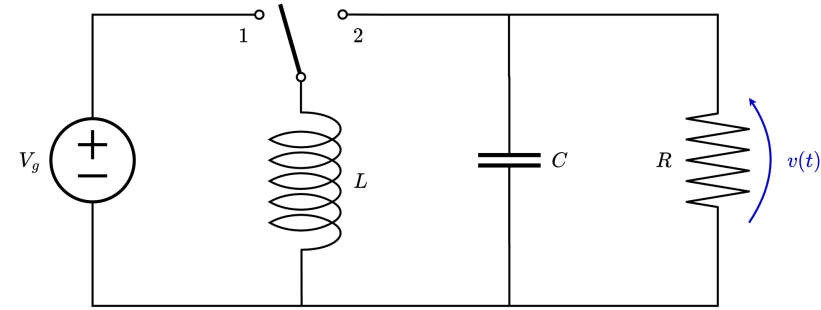

1. Find the conversion ratio $M(D) = \frac{V}{V_g}$.
2. Find the dependence between the inductor average current I_L and the other parameters (V_g , R and D).
3. Given the following specifications: $V_g = 30\text{ V}$, $V = -20\text{ V}$, $R = 4\ \Omega$ and $f_s = 40\text{ kHz}$, find D and I_L .
4. Calculate the value of L that will make the peak inductor current ripple Δi_L equal to 10% of the average inductor current I_L .
5. Including the effect of the inductor current ripple, sketch on the same figure:
 - The current flowing in the inductor
 - The current flowing in terminal 1 of the switch
 - The current flowing in terminal 2 of the switch

Answer:

1. $M(D) = \frac{-D}{1-D}$ 2. $I_L = \frac{-V}{R(1-D)} = \frac{D}{(1-D)^2} \frac{V_g}{R}$ 3. $D = 0.4$, $I_L = 8.33\text{ A}$ 4. $L = 180\ \mu\text{H}$